

Specification

Drawing No.	TKY1D-H1-14985-00 [12]-1/13
Issued Date.	December 26, 2014

TO: KED USA

Note: In case of specification change, KYOCERA Part Number also will be changed.

Product Name	Temperature Compensated Crystal Oscillator
Product Model	KT2520K
Frequency	26.0MHz
Customer Part Number	_____
Customer Specification Number	_____
KYOCERA Part Number	KT2520K26000DCW28QAS
Remarks	RoHS Compliant, MSL=1

Customer Acceptance

Accept Signature	Accept Date	
	Department	
	Person in charge	

Seller
 KYOCERA Crystal Device Corporation
 Crystal Products Sales Division
 6 Takeda Tobadono-cho, Fushimi-ku, Kyoto
 612-8501 Japan
 TEL. No. 075-604-3500
 FAX. No. 075-604-3501

Manufacturer
 Corporate Production Group
 Oscillator Division
 5850, Higashine-koh, Higashine-shi, Yamagata
 999-3701 Japan
 TEL. No. 0237-43-5611
 FAX. No. 0237-43-5615

Design Department	Quality Assurance	Approved by	Checked by	Issued by
	Oscillator Engineering Department Application Engineering Section	Y.Kakuta	Y.Yokoo	N.Nakano

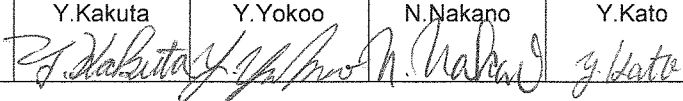

Revision History

Rev.No.	Description of revise	Date	Approved by	Checked by	Issued by
00	First Edition	Dec. 26, '14	Y.Yokoo	N.Nakano	Y.Kato

1. Purpose and scope

This document contains specification related to CRYSTAL OSCILLATOR model
KT2520K26000DCW28QAS for KED USA.

2. Nominal condition

	Item	MIN.	TYP.	MAX	Unit	Conditions
1	Operating temperature range	-30	---	+85	deg.C	
2	Storage temperature range	-40	---	+85	deg.C	
3	Nominal frequency	---	26.0	---	MHz	
4	Supply voltage	2.66	2.8	2.94	V	2.8V+/-5%
5	Absolute maximum rating voltage (Supply voltage)	-0.6	---	+4.6	V	
	Absolute maximum rating voltage (Control voltage)	-0.6	---	Vcc+0.6	V	
6	Load impedance	9	10	11	kohm	
		9	10	11	pF	
7	Output signal condition	---	Clipped sine	---		
8	Control voltage range	0.4	1.4	2.4	V	1.4V+/-1.0V

3. Electrical characteristics

Ta= -30 deg.C to +85 deg.C, Vcc=2.8V, Vcon=1.4V, Load 10kohm//10pF

	Item	MIN.	TYP.	MAX.	Unit	Conditions	Remarks
1	Temp characteristics	-2.0	---	+2.0	x10 ⁻⁶	On the basis of 25deg.C frequency	
2	Voltage characteristics	-0.2	---	+0.2	x10 ⁻⁶	2.8V+/-5%	
3	Load characteristics	-0.2	---	+0.2	x10 ⁻⁶	10kohm//10pF+/-10%	
4	Aging characteristics	-1.0	---	+1.0	x10 ⁻⁶ /Y	1year	at 25+/-2 deg.C
5	Frequency tolerance	-2.0	---	+2.0	x10 ⁻⁶	After 2 times reflow soldering	at 25+/-2 deg.C
6	Current	---	---	1.5	mA		
7	Output voltage	0.8	---	---	Vp-p		
8	Harmonics	---	---	-8.0	dBc		
9	Control voltage stability	-15.0	---	-9.0	x10 ⁻⁶	Vcon=0.4V	ref:Vcon=1.4V
		+9.0	---	+15.0	x10 ⁻⁶	Vcon=2.4V	
10	Terminal impedance	100	---	---	kohm		
11	Start up time	---	---	3.0	msec	90% of final output amplitude Within +/-1.0ppm	
12	Duty cycle	40	50	60	%	@GND	
13	Phase noise	---	---	-134	dBc/Hz	@1kHz offset	at -30 to 85 deg.C

4. Circuit

Bypass Capacitor and DC- Blocking Capacitor do not build in this TCXO.
 So, Bypass Capacitor and DC- Blocking Capacitor are attached outside and please use it.
 And these Capacitor should be placed as close as possible to the pin(No.4 and No.6).

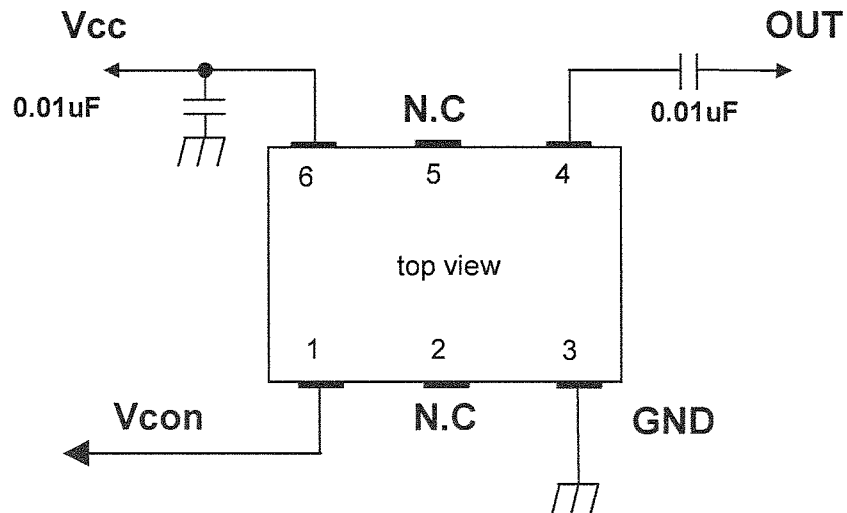

5. Test circuit

*Load $10k\Omega // 10pF$ contains the internal impedance of FET probe.

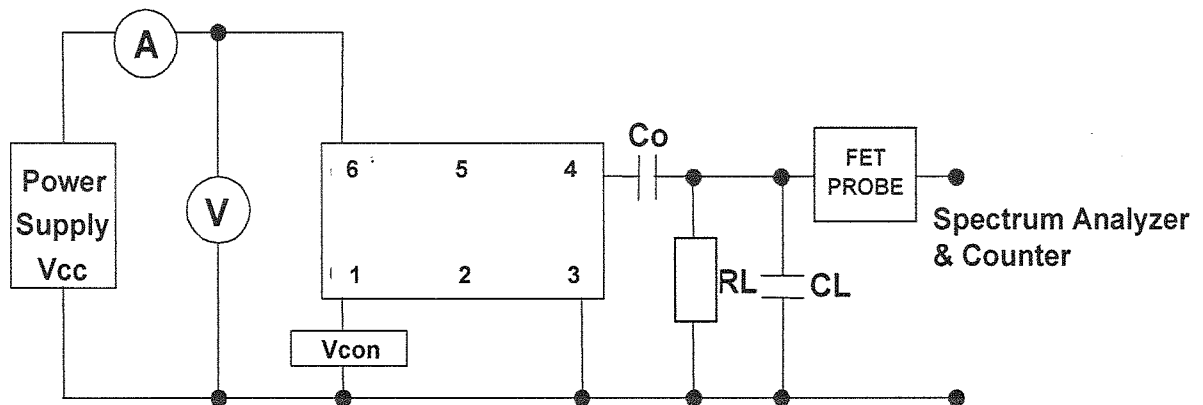

6. Environment mechanical characteristics

	Item	Conditions	Remark
1	High temperature storage	Ta=+85deg.C, judge on 240H storage	It must be met to the characteristics Judging criterion. Measurement shall be taken at room ambient within 2 to 24hours after each test.
2	Low temperature storage	Ta=-40deg.C, judge on 240H storage	
3	High temperature and high humidity storage	Ta=+85deg.C, RH=85%RH, judge on 240H storage	
4	Temperature cycle test	Ta=-40 to +85deg.C 30min. each 10cycles	
5	Drop test	A test piece (100g) made of Teflon is dropped 3cycles (1cycle: 6 directions) from the height of 150cm on hard board	
6	Vibration test	10 to 55 to 10Hz 1.5mm constant amplitude 1min. period X, Y, Z direction each 2H total 6H.	
7	Solder heat test	All terminal electrode shall be soldered at temperature of 350+/-5deg.C for 3+/-1sec. using a soldering iron.	
8	Solderability	Dip each of terminal electrode into 230+/-5deg.C solder pod for 5+/-0.5sec. after close, the test area of loads surfaces must be covered loads 90% by solder.	
9	Reflow soldering	Reflow soldering at 2times.	

Normal Condition: Temperature 25+/-2deg.C
Humidity 30 to 70%RH

Judge

Item	Specification
At 25deg.C frequency	+/-2.0ppm max(Before and After)

7. Reflow profile

7-1. Preheat: $180 \pm 0/-10$ deg.C, 120sec (max)

7-2. Peak Temperature: $260 \pm 0/-10$ deg.C, 10sec (max)

7-3. PC-Board

Material : FR-4

Size : 140mm*110mm

Thickness : $t=0.8$ mm

7-4. Condition of Measurement Temperature: Surface of PC-BOARD

7-5. Reflow Number of Time: 2times

Reflow Soldering Condition

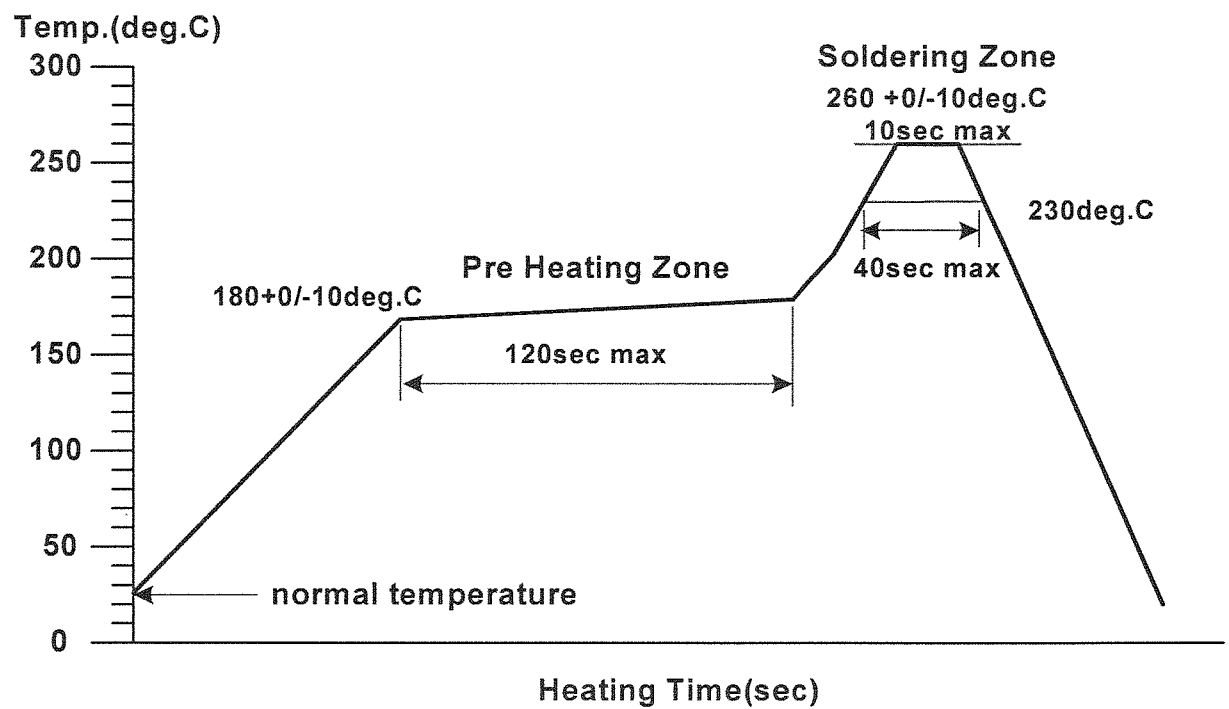

8. Marking contents

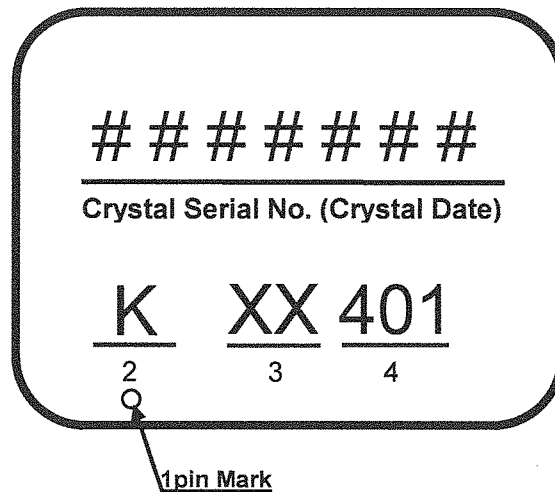

*Laser Marking

	Contents	Example
1	1Pin identifier	○
2	Control Code1	K
3	Control Code2	XX
4	Weekly Code.	401 *The 2014 1st week 402 *The 2014 2nd week

9. Dimensions

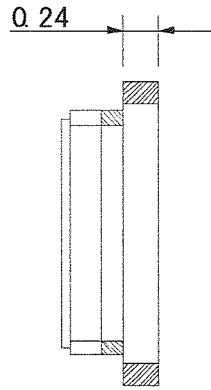
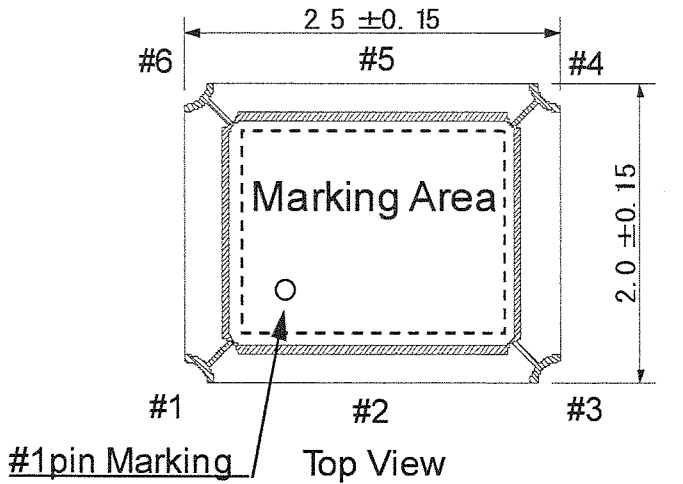

Side View

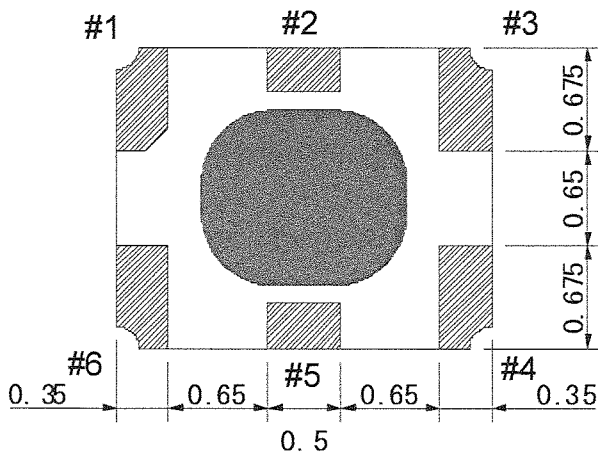

Bottom View

Land pattern (Reference)

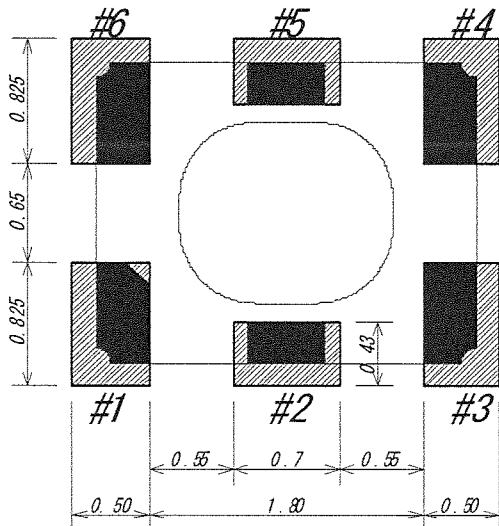

Note1

Terminal Coplanarity: 100um max

Note2

Electrode : Cu + Ni + Au

(15μ min + 3μ min + 0.03μ min)

	Pin Connection
# 1 pin	Vcon
# 3 pin	GND
# 4 pin	Output
# 6 pin	Vcc
# 2,5 pin	N.C.

Unit: mm

10. Tape & Reel

10-1. Tape specification

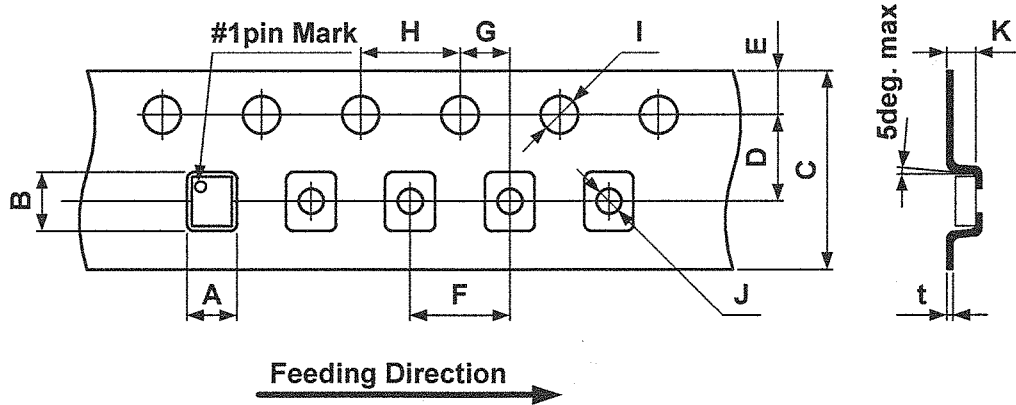

10-1-1. Carrier Tape material : PS Included Carbon

10-1-2. 1pin Mark is positioned on right side against the direction of feed.

Unit: mm

Symbol	A	B	C	D	E
Dimension	2.40 \pm 0.1	2.90 \pm 0.1	8.00 \pm 0.3/-0.2	3.50 \pm 0.05	1.75 \pm 0.1

Symbol	F	G	H	I	J
Dimension	4.00 \pm 0.1	2.00 \pm 0.05	4.00 \pm 0.1	Φ 1.5 \pm 0.1/-0	Φ 1.1 \pm 0.1

Symbol	K	t
Dimension	1.15 \pm 0.1	0.25 \pm 0.05

10-2. Reel specification

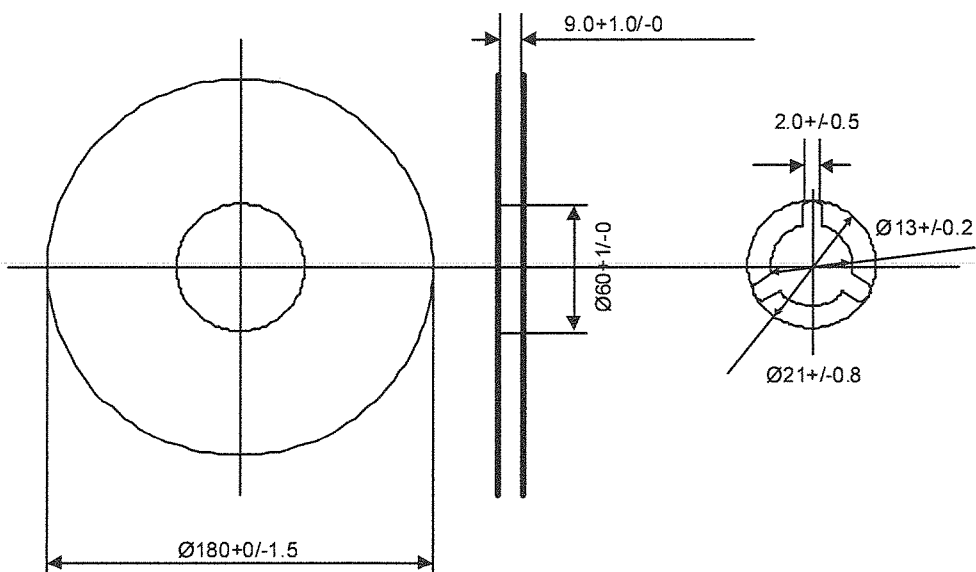

Unit: mm

10-2-1. Reel material: PS Included Carbon

10-2-2. Reel unit: 3,000pcs max. /1Reel

10-3.Packing

10-3-1.Trailer & Leader

As for the trailer and leader of taping, there are empty pockets as following drawing.
Sprocket hole is positioned on upper side against the direction of feed.
No missing components, excluding empty place.

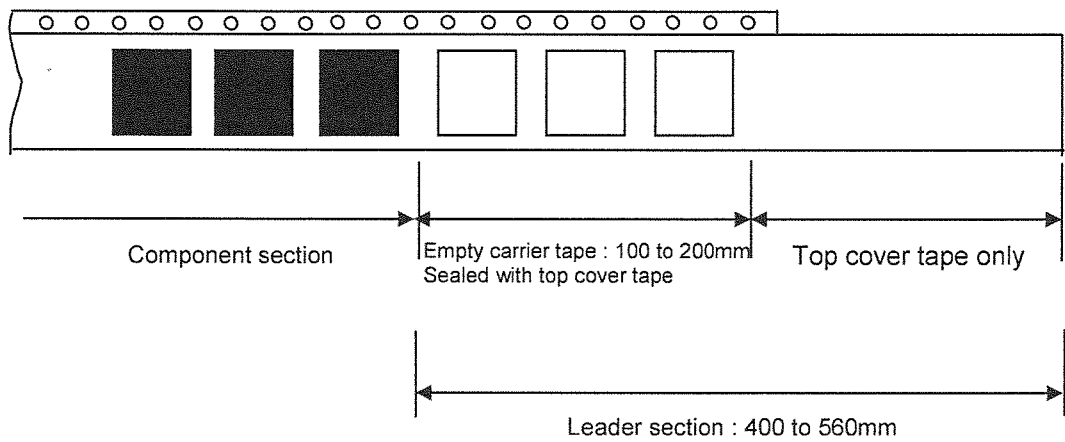
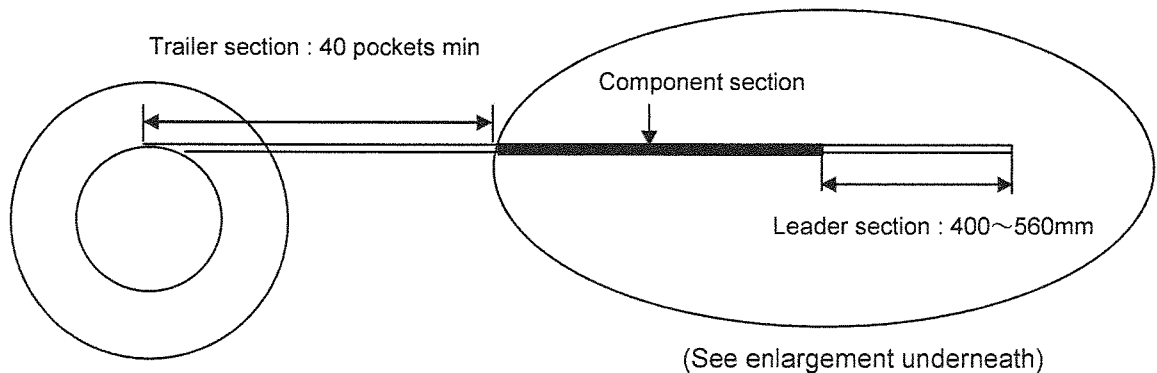

10-4. Shipping label

Following item shall be listed on reel, bag and box.

“Customer’s name”, “Parts No”, “Lot No”, “Quantity”, “Order No”, “Date of manufacture”

The form of the label conforms to JEITA standard pattern C-3.

11. Top Cover breaking and peeling force

11-1. Reel Angle: 165 to 180deg

11-2. Tape Break Force: 10N min

11-3. Top Cover Tape Strength: 10N min

11-4. Top Cover Tape Peel Force: 0.1 to 1.0N

11-5. Top Cover Tape Peel Speed: 300+/-10mm / minute

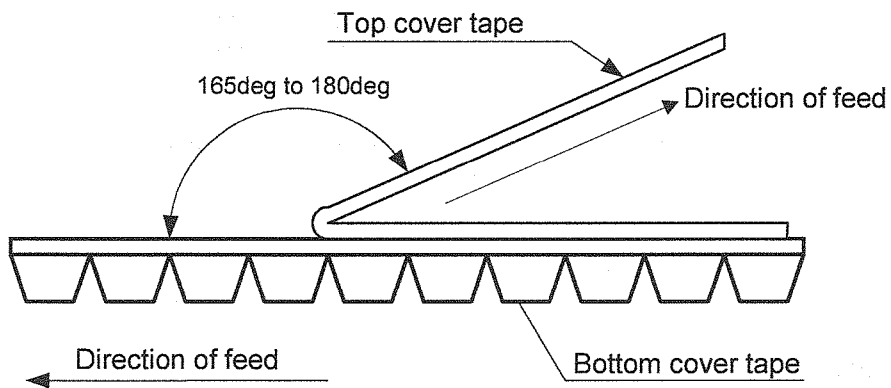

12. Notice

- 12-1. Please use soldering iron and the spot heater within the range of a solder heat test condition.
- 12-2. Units should be stored in a dry environment keeping away from the sun.
- 12-3. Don't leave units in High-temperature and High-humidity environment due to terminal solderability.
(Please keep 0 to 40deg.C and 30 to 70%RH for recommendable storage condition)
- 12-4. The term of a guarantee of taping packing is 6 months. (0 deg.C to 40 deg.C,RH30% to 70%)
- 12-5. Disapprove of washing.
- 12-6. Unless we receive request for modification within 1 month from the issue date of this KCD specification sheet, we will supply products according to this specification.
Also, if you'd like to modify specification of order, which has been placed with delivery within 1 month from the issue data of this specification sheet, we would like to discuss with you separately.
- 12-7. If you intend to use products listed on this specification for applications that may result in loss of life or assets (controls relating to safety, medical equipment, aeronautical equipment, space equipment, etc.), please do not fail to advise us of your intention beforehand.
- 12-8. In no event shall the company be liable for any product failure resulting from an inappropriate handling or operation of the product beyond the scope of its guarantee.
- 12-9. Information contained in this specification must not be quoted, reproduced or used for other purposes including processing either in part or in full without obtaining prior approval from the company.
- 12-10. Please keep it at the place that was the ESD protective.
Human model 1.5kohm 100pF : +/-1000V
Machine model 0kohm 200pF : +/-200V

13. Production place

13-1 Manufacturer

KYOCERA Crystal Device Corporation.

13-2 The site of the Factory

5850 Higasine-Koh, Higasine-shi, Yamagata, 999-3701, Japan

14. Parts Numbering Guide

KT2520K 26000 D C W 28 Q AS
A B C D E F G H

- A. Series (2.5x2.0 SMD KT2520K)
- B. Frequency (26.0MHz)
- C. Frequency temperature accuracy (D: +/-2.0ppm)
- D. Minimum temperature range (C: -30degC)
- E. Maximum temperature range (W: +85deg.C)
- F. Supply voltage (28: 2.8V)
- G. Control voltage stability (Q: +/-9.0 X10⁻⁶ to +/-15.0 X10⁻⁶ / 1.4V+/-1.0V)
- H. Customer special model Suffix