

4

3

2

1

THIS DRAWING IS UNPUBLISHED. RELEASED FOR PUBLICATION .19 .
 © COPYRIGHT 19 BY AMP INCORPORATED. ALL RIGHTS RESERVED.

PROD CODE	LOC	DIST	REVISIONS						
P	LTR	DESCRIPTION	DATE	DWN	APVD				
4595	DF	PO	C			REV & REDRAWN; 0600-1587-94 CT	6-94	CCT	JN

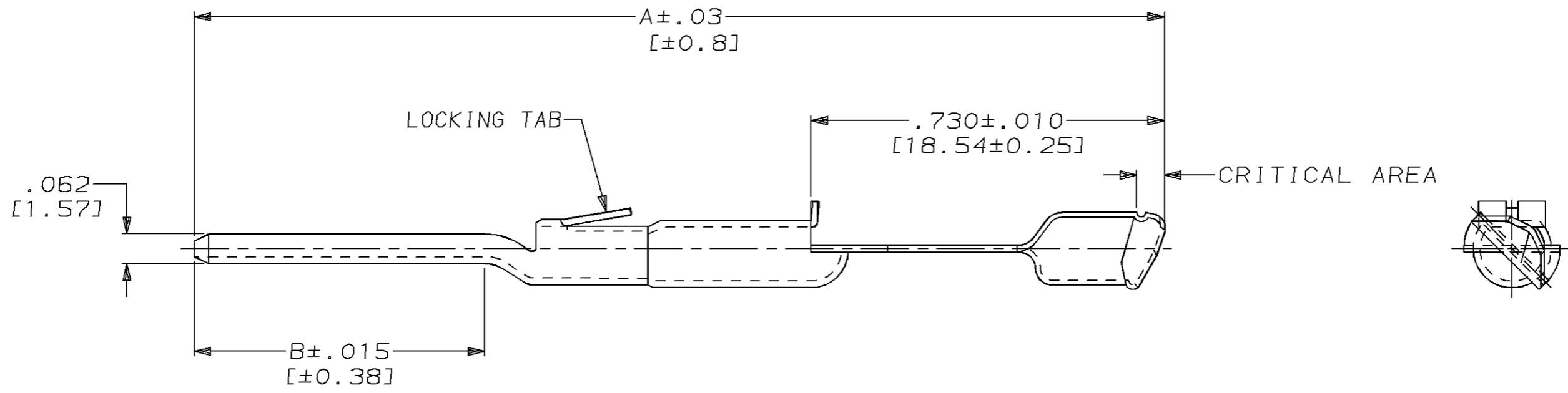
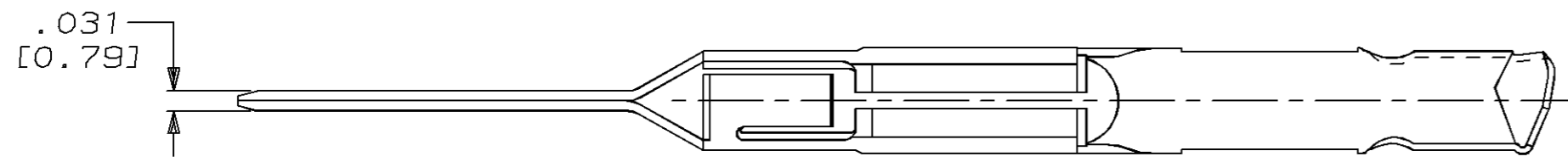

- 1 GOLD IN CRITICAL AREA ONLY, NICKEL ON ALL OF CONTACT.
- 2 GOLD IN CRITICAL AREA ONLY, NICKEL ON ALL OF CONTACT WITH LOCKING TAB DEPRESSED.
- 3 GOLD IN CRITICAL AREA ONLY, NICKEL ON ALL OF CONTACT WITH LOCKING TAB DEPRESSED.

.670 [17.02]	2.12 [53.85]	3	1-424156-6
.570 [14.48]	2.02 [51.31]	2	1-424156-2
.570 [14.48]	2.02 [51.31]	1	424156-8
DIM B	DIM A	FINISH	PART NO.

THIS DRAWING IS A CONTROLLED DOCUMENT FOR AMP INCORPORATED. IT IS SUBJECT TO CHANGE AND THE CONTROLLING ENGINEERING ORGANIZATION SHOULD BE CONTACTED FOR THE LATEST REVISION.		CHK C.C. THOMAS 6-6-94	DWN 6-6-94	AMP AMP Incorporated Harrisburg, PA 17105-3608
TOLERANCES UNLESS OTHERWISE SPECIFIED: 0 PLC ± - 1 PLC ± - 2 PLC ± - 3 PLC ± .005 [0.13] 4 PLC ± - ANGLES ± - FINISH SEE TABLE		APVD J. NORTON 6-7-94	NAME J. NORTON 6-7-94	
DIMENSIONS: INCHES [mm]		PRODUCT SPEC	APPLICATION SPEC	SPRING CONTACT, .031x.062, MODU POST, LEFT HAND
MATERIAL		WEIGHT	CUSTOMER DRAWING	
		SIZE	CAGE CODE	DRAWING NO
		A3	00779	C-424156
		SCALE	SHEET	REV
		4:1	1 OF 1	C