

THIS DRAWING IS UNPUBLISHED. RELEASED FOR PUBLICATION 20
 © COPYRIGHT 20 BY - ALL RIGHTS RESERVED.

LOC	DIST	REVISIONS					
CM	00	P	LTR	DESCRIPTION	DATE	DWN	APVD
			C3	REVISED PER ECO-11-023035	15NOV11	JR	TM

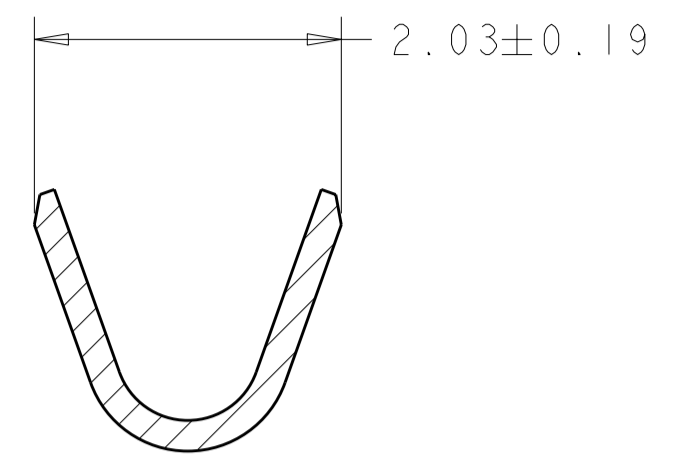

SECTION Y-Y
SCALE 20:1

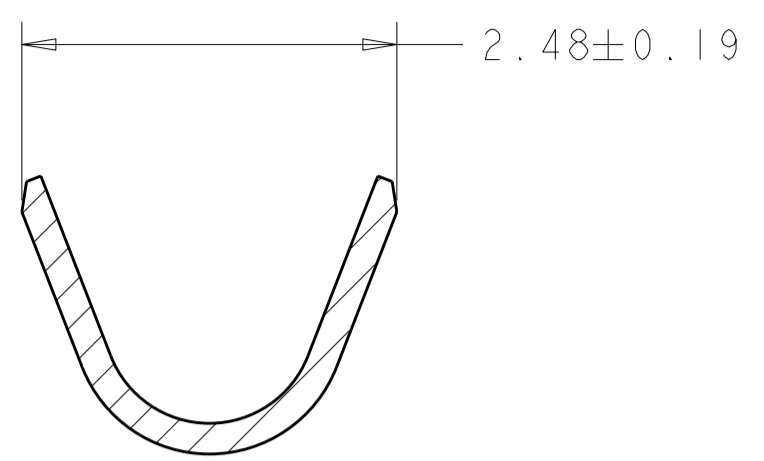

SECTION Z-Z
SCALE 20:1

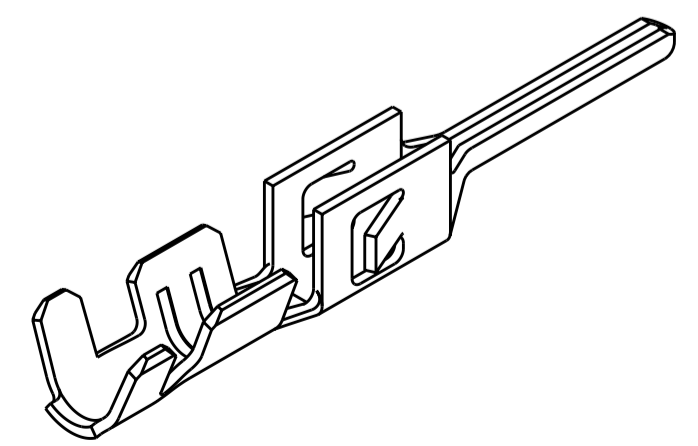
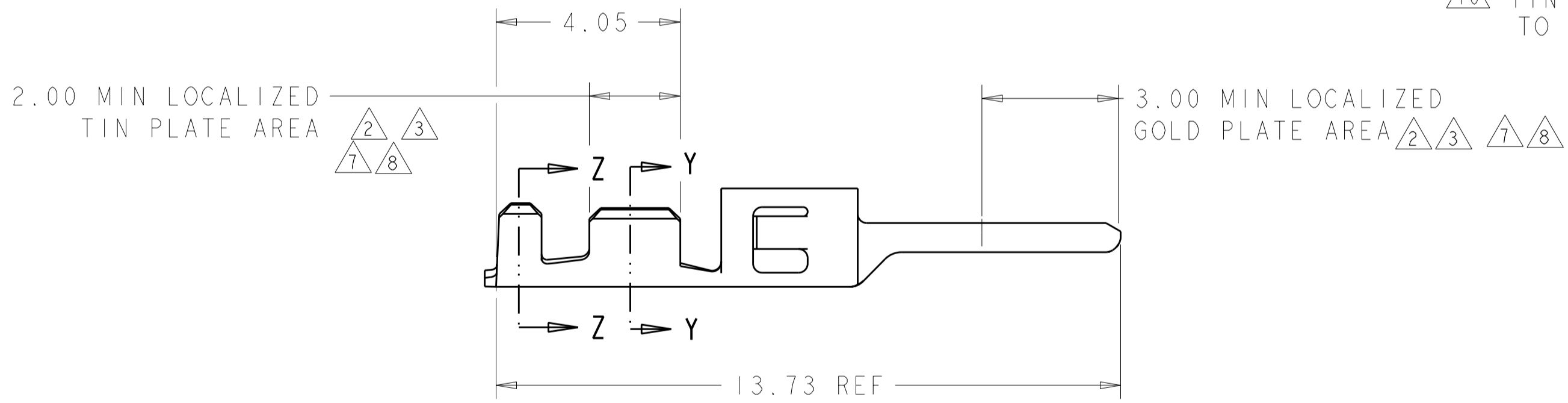
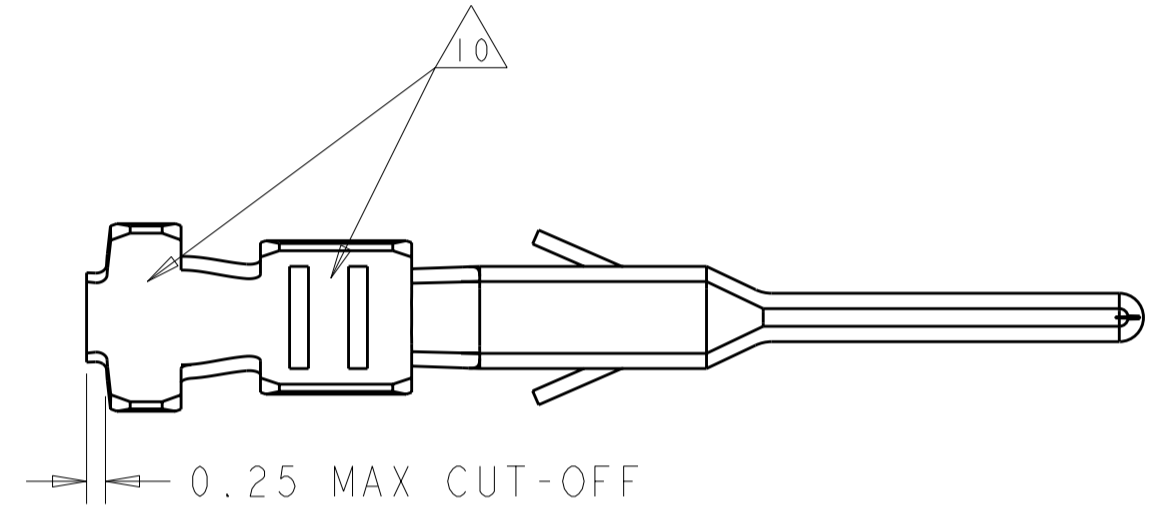

- 1. 2.54 μm MIN BRIGHT TIN/LEAD ENTIRE STOCK OVER 1.27 μm MIN NICKEL ENTIRE STOCK.
- 2. 0.38 μm MIN GOLD IN LOCALIZED GOLD PLATE AREA, 2.5 μm MIN BRIGHT TIN/LEAD IN LOCALIZED TIN/LEAD PLATE AREA, BOTH OVER 1.27 μm MIN NICKEL ON ENTIRE STOCK.
- 3. 0.76 μm MIN GOLD IN LOCALIZED GOLD PLATE AREA, 2.5 μm MIN BRIGHT TIN/LEAD IN LOCALIZED TIN/LEAD PLATE AREA, BOTH OVER 1.27 μm MIN NICKEL ON ENTIRE STOCK.
- 4. WIRE RANGE 20-24 AWG.
- 5. INSULATION RANGE 0.89-1.52
- 6. 2.54 μm MIN BRIGHT TIN ENTIRE STOCK OVER 1.27 μm MIN NICKEL ENTIRE STOCK.
- 7. 0.38 μm MIN GOLD IN LOCALIZED GOLD PLATE AREA, 2.5 μm MIN BRIGHT TIN IN LOCALIZED TIN PLATE AREA, BOTH OVER 1.27 μm MIN NICKEL ON ENTIRE STOCK.
- 8. 0.76 μm MIN GOLD IN LOCALIZED GOLD PLATE AREA, 2.5 μm MIN BRIGHT TIN IN LOCALIZED TIN PLATE AREA, BOTH OVER 1.27 μm MIN NICKEL ON ENTIRE STOCK.
- 9. NOTE DELETED.
- 10. TIN PLATING THICKNESS INSIDE WIRE AND INSULATION BARRELS TO BE 1.27 μm MIN.

1-794608-2	8	1-794612-2
1-794608-1	7	1-794612-1
1-794608-0	6	1-794612-0
794608-3	3	794612-3
794608-2	2	794612-2
794608-1	1	794612-1
REELED PART NUMBER	FINISH	LOOSE PIECE PART NUMBER

THIS DRAWING IS A CONTROLLED DOCUMENT.		DWN W J RUDY 29AUG2000	TE Connectivity	
DIMENSIONS: mm		CHK W DAVIS 29AUG2000		
TOLERANCES UNLESS OTHERWISE SPECIFIED:		APVD W DAVIS 29AUG2000	NAME PLUG CONTACT, CRIMP SNAP, 20-24 AWG LOOSE PIECE, MICRO MATE-N-LOK(TM)	
0 PLC ± 1 PLC ± 2 PLC ±0.13 3 PLC ± 4 PLC ±		PRODUCT SPEC -	SIZE A200779	
MATERIAL 0.20 THK BRASS		APPLICATION SPEC -	CAGE CODE C-794612	
ANGLES ± FINISH		WEIGHT -	DRAWING NO -	
CUSTOMER DRAWING		SCALE 10:1		SHEET 1 OF 1 REV C3