

3MHz 4A High Efficiency Step-Down Converter with I²C Interface

Purpose

The RT8092 is a Peak-Current Mode Pulse-Width-Modulated (PWM) step-down DC/DC converter with I²C control interface. The input voltage range from 2.5V to 5.5V and provides 4A output current. This document explains the function and use of the RT8092 evaluation board (EVB), and provides information to enable operation, modification of the evaluation board and circuit to suit individual requirements.

Table of Contents

Purpose	1
Introduction.....	2
Key Performance Summary Table	3
Bench Test Setup Conditions	3
Schematic, Bill of Materials & Board Layout	5
More Information.....	8
Important Notice for Richtek Evaluation Board	8

Introduction

General Product Information

The RT8092 is a Peak-Current Mode Pulse-Width-Modulated (PWM) step-down DC/DC converter with I²C control interface. Capable of delivering 4A continuing output current over a wide input voltage range from 2.5V to 5.5V, the RT8092 is ideally suited for portable electronic devices that are powered from 1-cell Li-ion battery or from other power sources within the range such as cellular phones, PDAs and handy-terminals.

Internal synchronous rectifier with low R_{DS(ON)} dramatically reduces conduction loss at PWM mode. No external Schottky barrier diode is required in practical application. The RT8092 enters low-dropout mode when normal PWM cannot provide regulated output voltage by continuously turning on the upper P-MOSFET. The RT8092 enters shutdown mode and consumes less than 5 μ A when the EN pin is pulled low. The switching ripple is easily smoothed out by small package filtering elements due to a fixed operation frequency of 3MHz. Along with its small WL-CSP-15B 1.2x2 (BSC) package, it is suitable for applications requiring small PCB area. To increase battery life time, the RT8092 provides low power mode with I_Q < 15 μ A in standby and light-load applications. The RT8092 also includes Dynamic Voltage Scaling (DVS) for system low power applications.

The I²C interface let the RT8092 controllable flexibly to select V_{OUT} voltage level, peak current limit level, PWM control mode, and so on. Other features include soft-start, auto discharge, lower internal reference voltage, overtemperature, and over-current protection.

Product Feature

- **2.5V to 5.5V Input Range**
- **Low Operation Quiescent Current**
 - ▶ Normal Mode I_Q < 60 μ A
 - ▶ Low Power Mode I_Q < 15 μ A
- **Output range From 0.3V to 5.5V**
 - ▶ Bank 0 : 0.3V to 0.7V
 - ▶ Bank 1 : 0.6V to 1.4V
 - ▶ Bank 2 : 1.2V to 2.8V
 - ▶ Bank 3 : 2.4V to 5.5V
 - ▶ The Default Value is 2.8V (VSEL = High) and 1V (VSEL = Low)
- **4A Continuing Output Current**
- **Support DVS in the Same Bank**
 - ▶ V_{OUT} Adjusting Range (max, min) is Settable
- **High Efficiency**
 - ▶ 90% at 5V \rightarrow 2.8V with 1.5A Load
- **3MHz Fixed-Frequency PWM Operation**
 - ▶ Auto-PSM/PWM or Force-PWM Selectable
- **Support Remote Ground Sensing for Accurate Output Voltage**

Key Performance Summary Table

Key Features		Evaluation Board Number : PCB016_V1
Default Input Voltage	3.3V	
Max Output Current	4A	
Default Output Voltage	1.0V with VSEL = L	
Default Marking & Package Type	RT8092URWSC, WL-CSP-15B 1.2x2 (BSC)	
Operation Frequency	Steady 3MHz at all loads	

Bench Test Setup Conditions

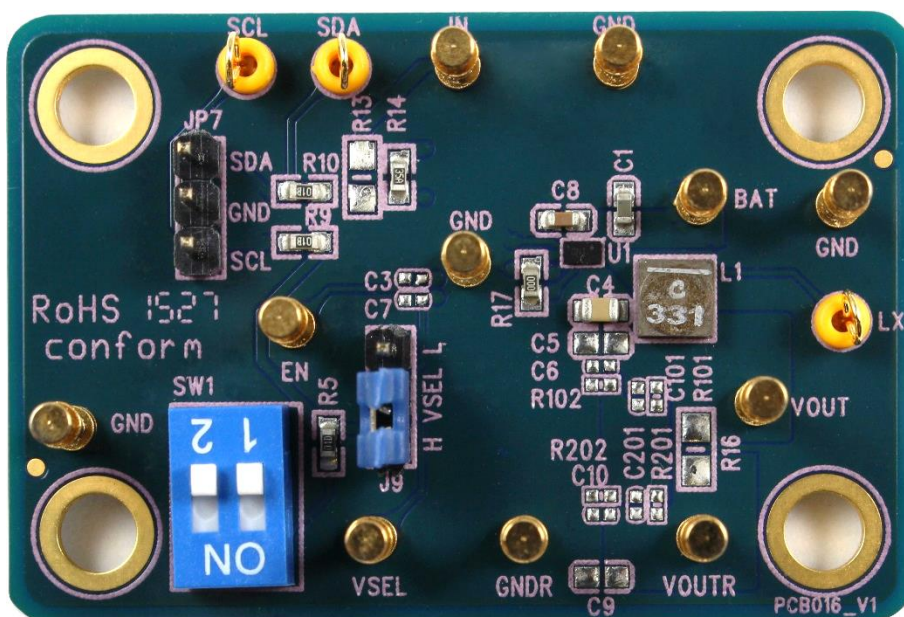

Please carefully inspect the EVB IC and external components, comparing them to the following Bill of Materials, to ensure that all components are installed and undamaged. If any components are missing or damaged during transportation, please contact the distributor or send e-mail to evb_service@richtek.com.

Test Points

The EVB is provided with the test points and pin names listed in the table below.

Test point/ Pin name	Signal	Comment (expected waveforms or voltage levels on test points)
BAT	Input voltage	Power input. Support 2.5V to 5.5V Input Voltage. Must bypass with a suitable large ceramic capacitor at this pin.
EN	Enable test point	High = Enable.
GND	Ground	Ground.
VSEL	Nominal VOUT setting select input pin	VSEL = Low selects {0x11.ENSEL0, 0x11.VoutSEL0[6:0], 0x14.PWM0}. VSEL = High selects {0x10.ENSEL1, 0x10.VoutSEL1[6:0], 0x14.PWM1}.
VOUT	Output voltage	Power output. Must bypass with a suitable large ceramic capacitor at this pin.

Test point/ Pin name	Signal	Comment (expected waveforms or voltage levels on test points)
VOUTR	Output Voltage Sense Input	Output feedback pin.
GNDR	Remote Ground Sense Input	Connect to GND as short as possible.
LX	Switch node test point	Connect this pin to an external L-C filter.

Power-up & Measurement Procedure

1. Connect input power ($2.5V < V_{IN} < 5.5V$) and input ground to VIN and GND test pins respectively.
2. Connect positive end and negative terminals of load to VOUT and GND test pins respectively.
3. There is a 2-pin switch “EN” for enable control. To switch up position to tie EN test pin to input power VBAT for enabling the device. Inversely, to switch down position to tie EN test pin and ground GND for disabling the device.
4. Verify the output voltage (1.0V with VSEL = L or 2.8V with VSEL = H) between VOUT and GND.
5. Connect an external load up to 4A to the VOUT and GND terminals and verify the output voltage and current.

Output Voltage Setting

Set the output voltage by VSEL pin between BAT and GND. There is a 3-pin header “VSEL” for VOUT selection. To use a jumper at “H” option to tie VSEL test pin to input power BAT for VOUT = 2.8V (dafult setting). Inversely, to use a jumper at “L” option to tie VSEL test pin to ground GND for VOUT = 1.0V (default setting).

Schematic, Bill of Materials & Board Layout

EVB Schematic Diagram

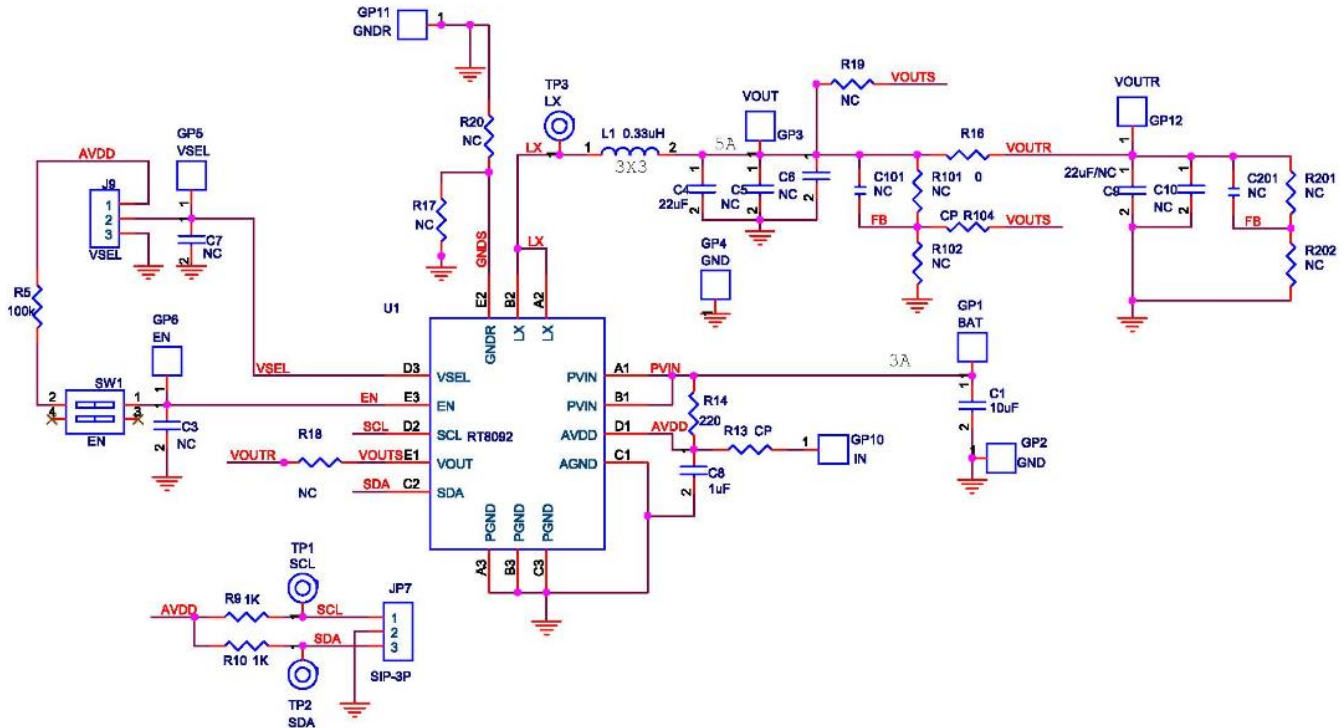

Bill of Materials

Reference	Qty	Part Number	Description	Package	Manufacture
U1	1	RT8092URWSC	Buck Converter	WL-CSP-15B 1.2x2 (BSC)	RICHTEK
C1	1	0603X106M6R3	10µF/6.3V/X5R	C-0603	WALSIN
C4	1	C2012X5R0J226K	22µF/6.3V/X5R	C-0805	TDK
C8	1	C1608X5R0J1A104K	1µF/6.3V/X5R	C-0603	TDK
R5	1	RM06FTN1005	100k/1%/0603	R-0603	WALSIN
R14	1	RM06FTN2202	220/1%/0603	R-0603	TA-I
R9, R10	2	RM06FTN1003	1k/1%/0603	R-0603	WALSIN
L1	1	XFL4015-331MEC	0.33µH/R33C	L-4015	Coilcraft

PCB Layout

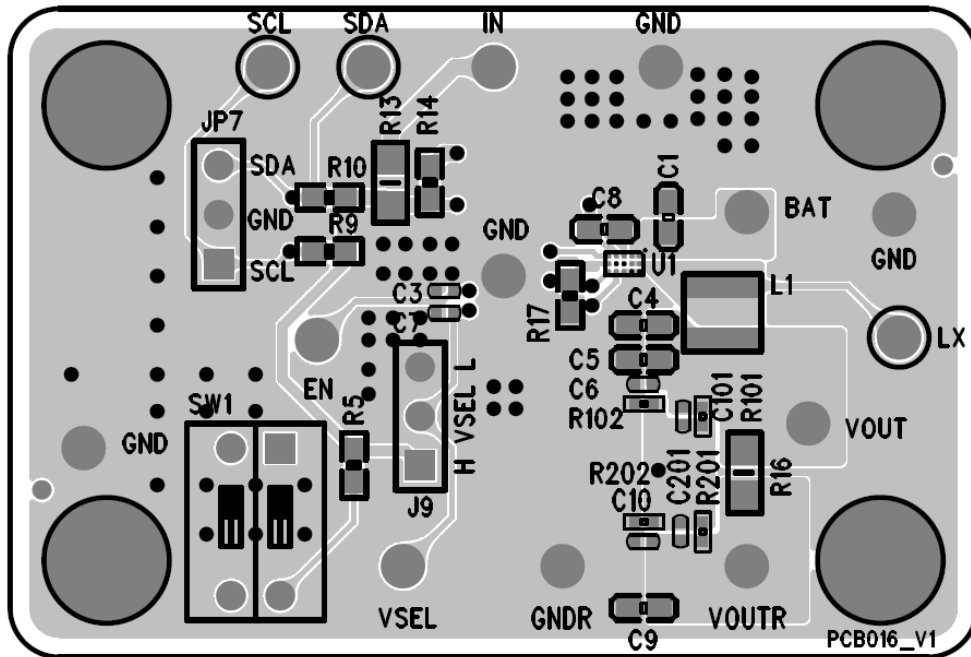

Top View (1st layer)

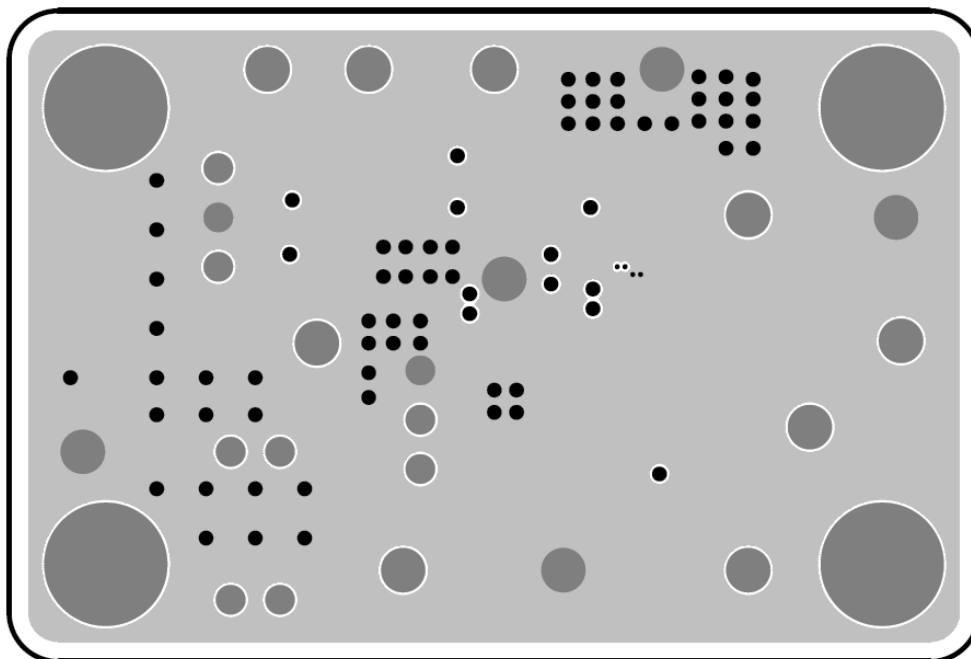

PCB Layout—Inner Side (2nd Layer)

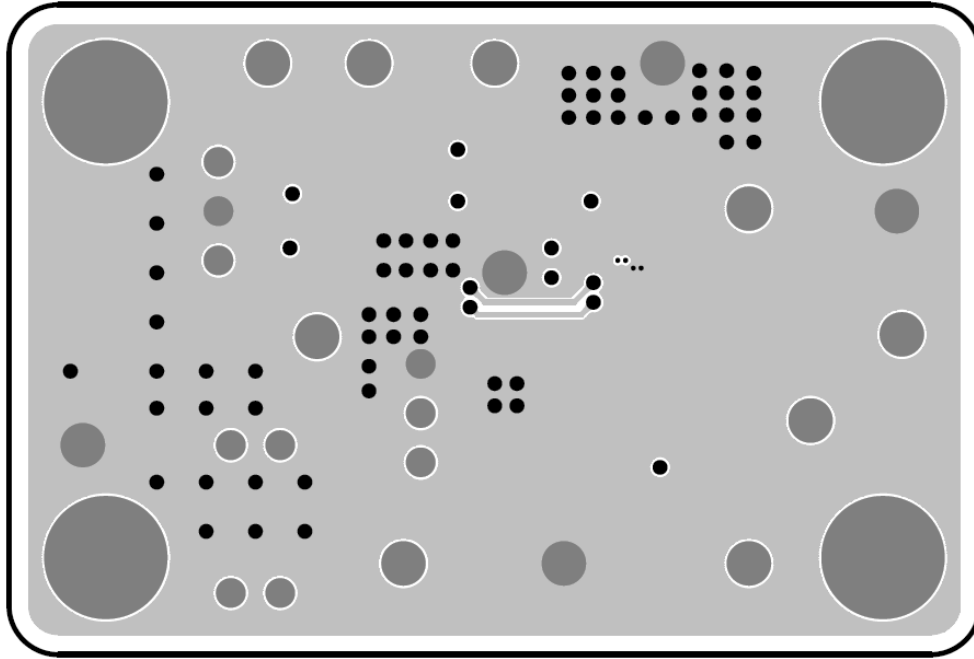

PCB Layout—Inner Side (3rd Layer)

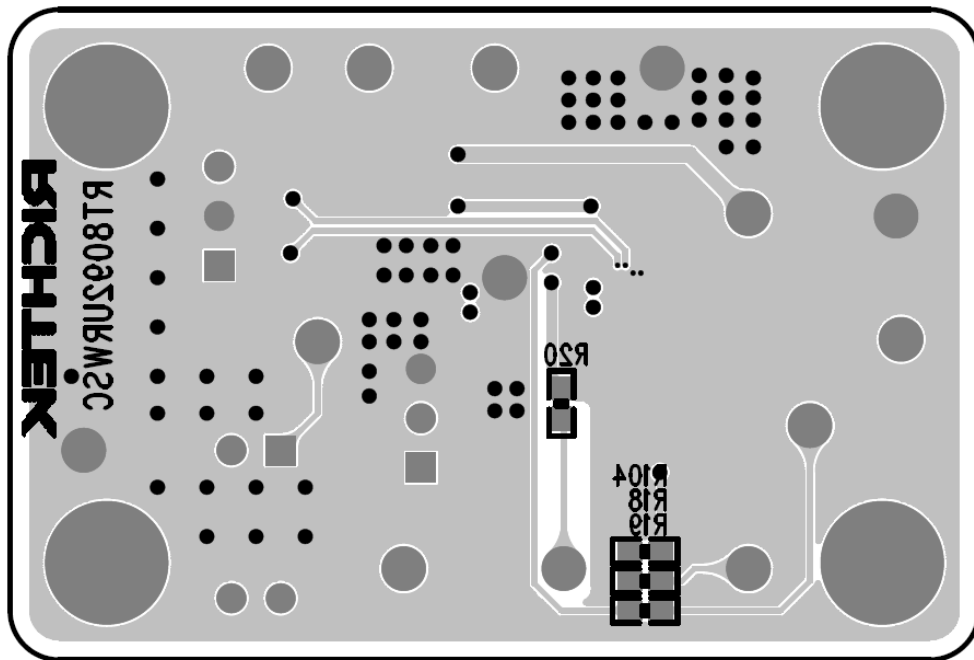

Bottom View (4th Layer)

More Information

For more information, please find the related datasheet or application notes from Richtek website <http://www.richtek.com>.

Important Notice for Richtek Evaluation Board

THIS DOCUMENT IS FOR REFERENCE ONLY, NOTHING CONTAINED IN THIS DOCUMENT SHALL BE CONSTRUED AS RICHTEK'S WARRANTY, EXPRESS OR IMPLIED, UNDER CONTRACT, TORT OR STATUTORY, WITH RESPECT TO THE PRESENTATION HEREIN. IN NO EVENT SHALL RICHTEK BE LIABLE TO BUYER OR USER FOR ANY AND ALL DAMAGES INCLUDING WITHOUT LIMITATION TO DIRECT, INDIRECT, SPECIAL, PUNITIVE OR CONSEQUENTIAL DAMAGES.