

Aug.1.2018 Copyright 2018 HIROSE ELECTRIC CO., LTD. All Rights Reserved.
 In case that the application demands a high level of reliability, such as automotive,
 please contact a company representative for further information.

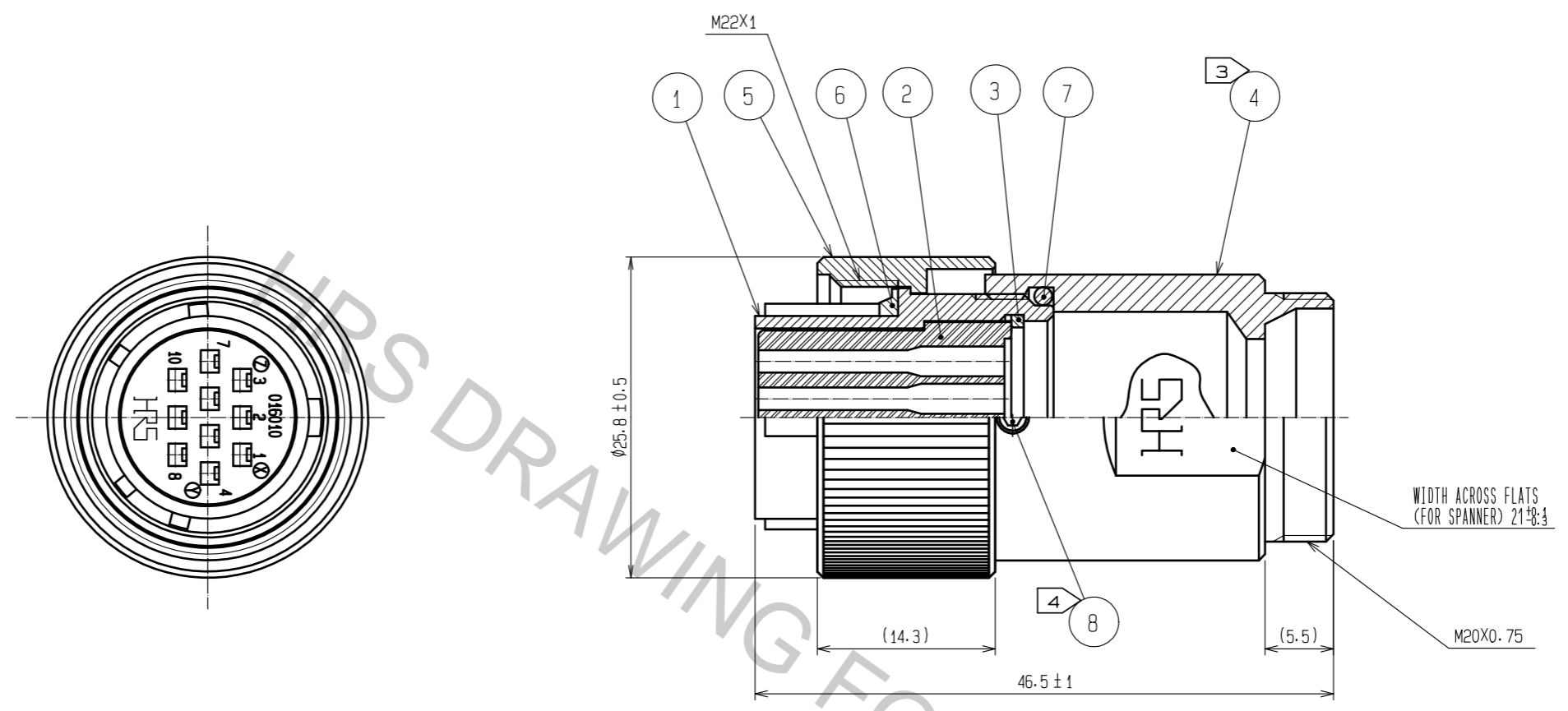

- NOTES 1 APPLICABLE CRIMP CONTACT: JRC-SC2-212(AWG#20 TO 24)
 JRC-SC2-222(AWG#24 TO 28)
- 2 APPLICABLE CONTACT REMOVAL TOOL(EXTRACTION TOOL): RM-TP
- ③ THE RECOMMENDED CLAMP TORQUE, REF. NO. ④: 3 TO 3.5N · m.
- ④ THE RECOMMENDED CLAMP TORQUE, REF. NO. ⑧: 0.2 TO 0.25N · m.
 AND LOCTITE 263, HENKEL JAPAN OR EQUIVALENT IS RECOMMENDED TO
 PREVENT FROM LOOSENING.
- 5 ONE EXAMPLE OF THE ROTATION OF REF. NO. ④ TO REF. NO. ① IS SHOWN.
- 6 THIS PRODUCT TO BE USED WITH CABLECLAMP, JR16WCC-※.
 ※ DESIGNATE DIAMETER OF APPLICABLE CABLE.
- 7 THE CABLE PULL AND TWISTING STRENGTH AND OTHER CHARACTERISTICS MAY DIFFER,
 DEPENDING ON THE CABLE STRUCTURE.
 PLEASE CONFIRM BEFORE THE USE.

4	BRASS	BLACK CHROME PLATING	8	STAINLESS STEEL	
3	PHOSPHOR BRONZE	NICKEL PLATING	7	ACRYLONITRILE BUTADIENE RUBBER	(BLACK)
2	POLYCARBONATE	(BLACK) UL94V-0	6	ACRYLONITRILE BUTADIENE RUBBER	(BLACK)
1	ALUMINUM ALLOY	BLACK CHROME PLATING	5	BRASS	BLACK CHROME PLATING
NO.	MATERIAL	FINISH . REMARKS	NO.	MATERIAL	FINISH . REMARKS

UNITS mm		SCALE 2 : 1	COUNT 	DESCRIPTION OF REVISIONS	DESIGNED	CHECKED	DATE
HIROSE ELECTRIC CO., LTD.				APPROVED : HY. KOBAYASHI 18.02.26 CHECKED : HY. KOBAYASHI 18.02.26 DESIGNED : TH. KAMEYA 18.02.24 DRAWN : MK. INOUE 18.02.14	DRAWING NO. EDC-110655-31-00 PART NO. JR16WP-10SC(31) CODE NO. CL114-2122-0-31		