

Execution: Press-Fit
Surface coating 5-10µm Sn on 2-4µm Cu

(PROJECTION)		(TOLERANCES)	DIN ISO 2768-m	(SURFACE)	SCALE	2:1	TOTAL WEIGHT: 7,9 g
					(MATERIAL)	CuZn39Pb3	WEIGHT Cu: 0,0258 g
					(TITLE)	Bush with threaded hole M6 full plain Pin-Plate	
			DATE	NAME	(DRAWING NUMBER)	7461097	Sheet 1
			DRAWN	2009/09/04	Dino Cantara		1
			VERIFIED	2009/09/04	Heiko Schmid		
CONFIDENTIAL !! ALL RIGHTS RESERVED. Passing on or duplication without prior written agreement prohibited.							

1

2

3

4

A

Drill hole specification for chemical surfaces

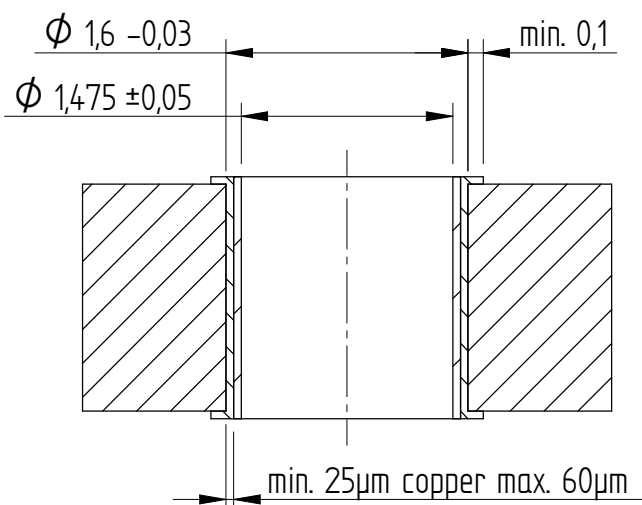

B

C

Drill hole specification for HAL

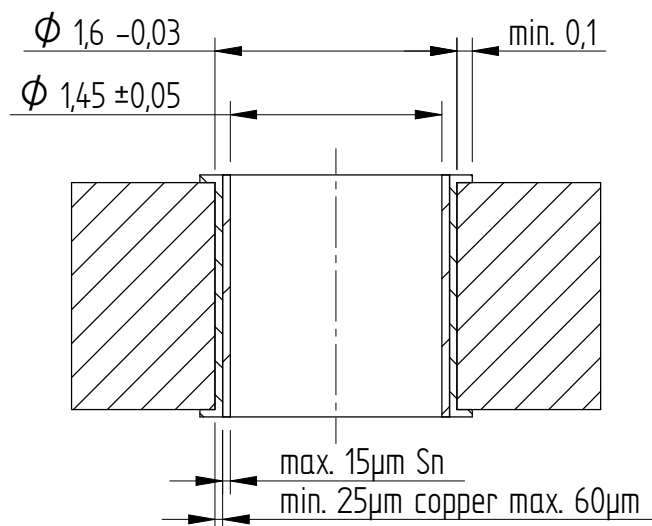

D

E

This electronic component is designed and developed with the intention for use in general electronics equipments. Before incorporating the components into any equipments in the field such as aerospace, aviation, nuclear control, submarine, transportation, (automotive control, train control, ship control), transportation signal, disaster prevention, medical, public information network etc. where high safety and reliability are especially required or if there is possibility of direct damage or injury to human body, Würth Elektronik must be asked for a written approval. In addition, even electronic component in general electronic equipments, when used in electrical circuits that require high safety, reliability functions or performance, the sufficient reliability evaluation-check for the safety must be performed before by the user before usage.

F

(PROJECTION)

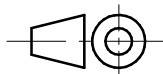

(TOLERANCES)

DIN ISO 2768-m

(SURFACE)

SCALE 20:1

(MATERIAL)

DATE

NAME

DRAWN 2013/08/27 Dino Cantara

VERIFIED 2013/08/27 Wladimir Werz

(TITLE)

Power Elements Specification

Press-fit system

(DRAWING NUMBER)

Sheet 1

1



ISSUE

CHANGE

DATE

NAME

CONFIDENTIAL !! ALL RIGHTS RESERVED. Passing on or duplication without prior written agreement prohibited.