

NOTES:

1. ROHS COMPLIANT
2. HEADER: PHENOLIC WITH FLAMMABILITY RATING UL 94V-0 OR BETTER.
3. STORAGE TEMPERATURE: -50°C TO +125°C
4. COMPLIANCE TO J-STD:
 - A. J-STD-002: SOLDERABILITY AT 245°C REFLOW PROFILE
 - B. J-STD-020: LEVEL 1, NO MOISTURE SENSITIVE
 - C. J-STD-075: R7, 245°C MAXIMUM THROUGH REFLOW SOLDER
5. TO ORDER TAPE & REEL PACKAGING ADD A "T" SUFFIX TO THE PART NUMBER(i.e TX1514FNL BECOMES TX1514FNLT).

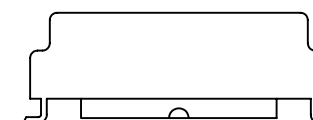
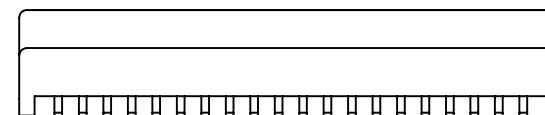
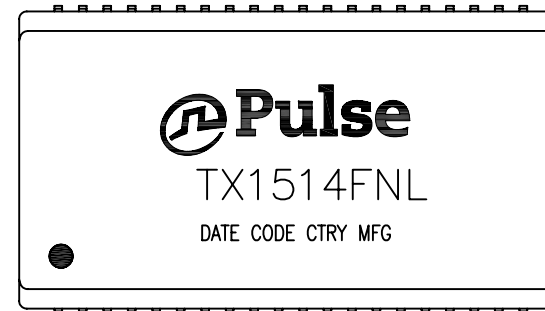

FINAL OUTLINE

© Copyright, 2014. Pulse Electronics Corp. All rights reserved. Pulse confidential & proprietary. (06/17/14)

PRODUCT DESCRIPTION	TLA DRAWING	PS DRAWING	SHEET	PART NO.	DATASHEET REV.
XFMR+CHOKE,OCT,T1,40PIN,1:2.42,1:1,NL	TX1514FNL-10	PS-2743.001-A	1 OF 3	TX1514FNL	A

ELECTRICAL CHARACTERISTICS AT +25°C UNLESS OTHER SPECIFIED

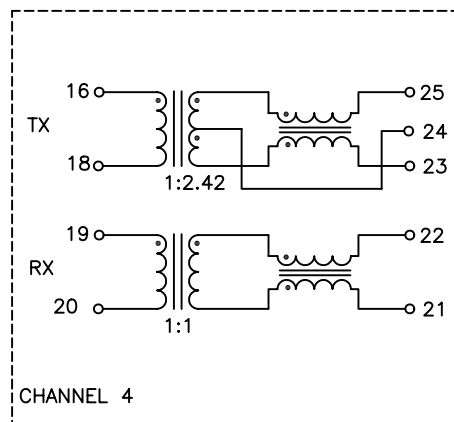
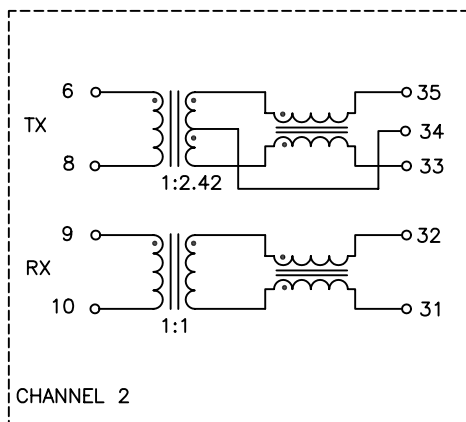
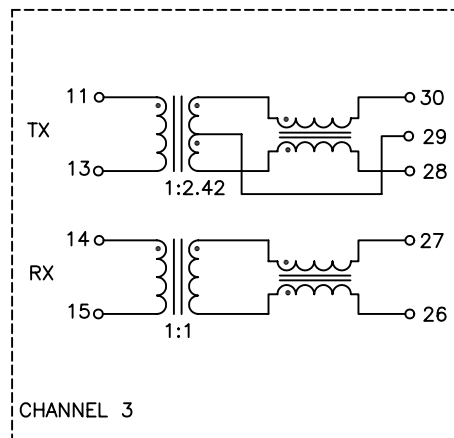
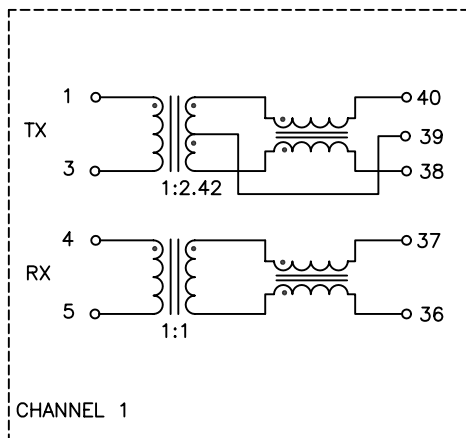

PARAMETER	SPECIFICATIONS
OPERATING TEMPERATURE	-40°C ~ +85°C
POLARITY	PER SCHEMATIC
TURNS RATIO: @10KHz, 0.02VRMS:	$\frac{40-38}{1-3} = \frac{35-33}{6-8} = \frac{30-28}{11-13} = \frac{25-23}{16-18} = 2.42 \pm 2\%$ $\frac{37-36}{4-5} = \frac{32-31}{9-10} = \frac{27-26}{14-15} = \frac{22-21}{19-20} = 1.0 \pm 2\%$
INDUCTANCE (OCL): @10KHz, 0.1VRMS	$(1-3)=(4-5)=(6-8)=(9-10) = 1.0 \text{ mH MIN}$ $(11-13)=(14-15)=(16-18)=(19-20) = 1.0 \text{ mH MIN}$
LEAKAGE INDUCTANCE (LL) @100 KHz, 0.02 VRMS	$(1-3) \text{ WITH } (40-38) \text{ SHORTED} = 1.0 \text{ uH MAX}$ $(4-5) \text{ WITH } (37-36) \text{ SHORTED} = 1.0 \text{ uH MAX}$ $(6-8) \text{ WITH } (35-33) \text{ SHORTED} = 1.0 \text{ uH MAX}$ $(9-10) \text{ WITH } (32-31) \text{ SHORTED} = 1.0 \text{ uH MAX}$ $(11-13) \text{ WITH } (30-28) \text{ SHORTED} = 1.0 \text{ uH MAX}$ $(14-15) \text{ WITH } (27-26) \text{ SHORTED} = 1.0 \text{ uH MAX}$ $(16-18) \text{ WITH } (25-23) \text{ SHORTED} = 1.0 \text{ uH MAX}$ $(19-20) \text{ WITH } (22-21) \text{ SHORTED} = 1.0 \text{ uH MAX}$
CWW @ 100 KHz, 0.02 VRMS	$(1-3) \text{ TO } (40-38) = 35 \text{ pF MAX}$ $(4-5) \text{ TO } (37-36) = 35 \text{ pF MAX}$ $(6-8) \text{ TO } (35-33) = 35 \text{ pF MAX}$ $(9-10) \text{ TO } (32-31) = 35 \text{ pF MAX}$ $(11-13) \text{ TO } (30-28) = 35 \text{ pF MAX}$ $(14-15) \text{ TO } (27-26) = 35 \text{ pF MAX}$ $(16-18) \text{ TO } (25-23) = 35 \text{ pF MAX}$ $(19-20) \text{ TO } (22-21) = 35 \text{ pF MAX}$
DCR	$(1-3)=(4-5)=(6-8)=(9-10) = 0.8 \text{ OHMS MAX}$ $(11-13)=(14-15)=(16-18)=(19-20) = 0.8 \text{ OHMS MAX}$
HIPOT (Pri TO Sec)	1500 VRMS FOR 60 SECONDS

© Copyright, 2014. Pulse Electronics Corp. All rights reserved. Pulse confidential & proprietary. (06/17/14)

PRODUCT DESCRIPTION	TLA DRAWING	PS DRAWING	SHEET	PART NO.	DATASHEET REV.
XFMR+CHOKE,OCT,T1,40PIN,1:2.42,1:1,NL	TX1514FNL-10	PS-2743.001-A	2 OF 3	TX1514FNL	A

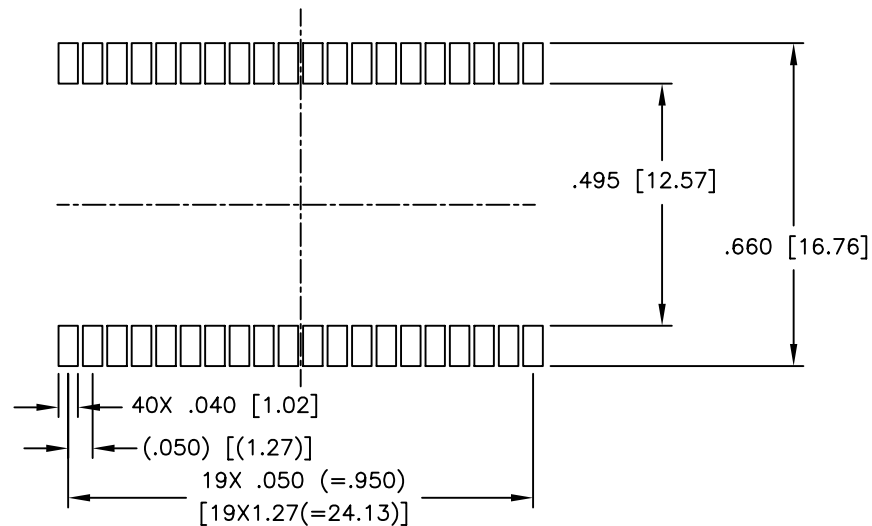
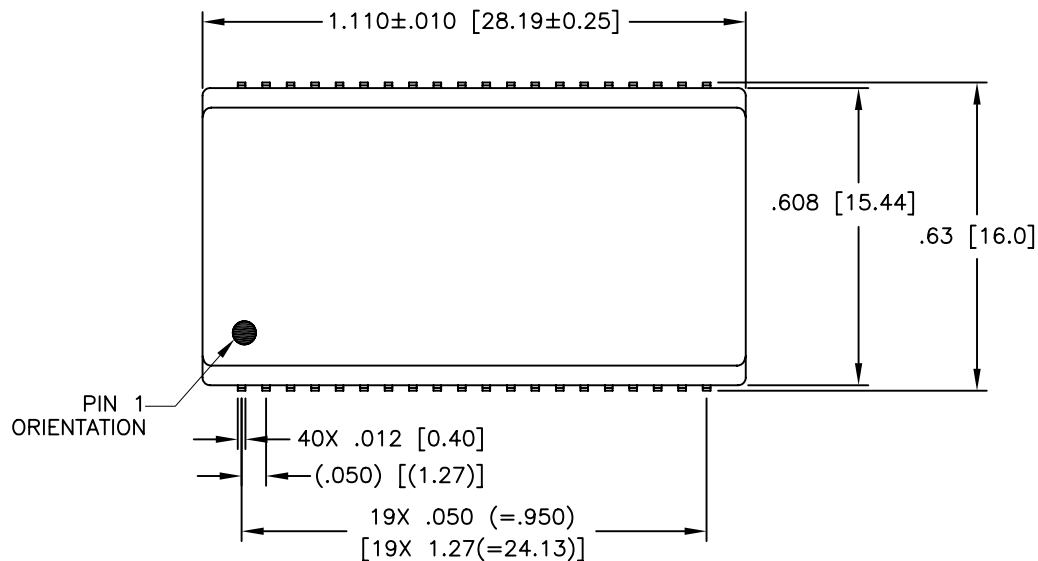

SUGGESTED PAD LAYOUT

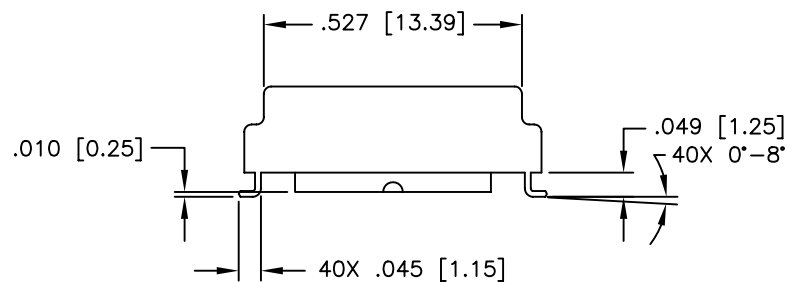
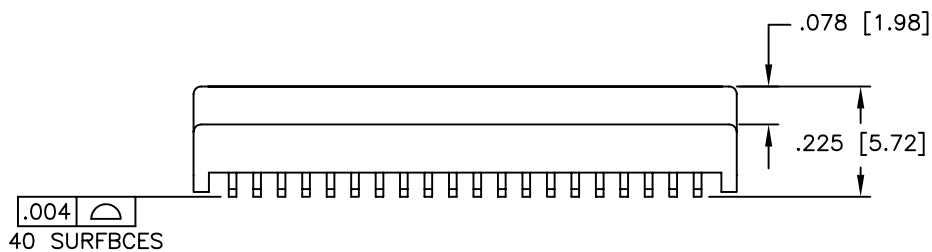

DIMENSIONS ARE IN INCHES [MILLIMETERS] WITH THE FOLLOWING TOLERANCES: [MILLIMETERS] ARE FOR REFERENCE ONLY.
 .XX= ±.01 [±0.25]
 .XXX= ±.005 [±0.13]

© Copyright, 2014. Pulse Electronics Corp. All rights reserved. Pulse confidential & proprietary. (06/17/14)

PRODUCT DESCRIPTION	TLA DRAWING	PS DRAWING	SHEET	PART NO.	DATASHEET REV.
XFMR+CHOKE,OCT,T1,40PIN,1:2.42,1:1,NL	TX1514FNL-10	PS-2743.001-A	3 OF 3	TX1514FNL	A