

PART NUMBER	REV	TERMINATOR	FEED TYPE	DESCRIPTION
1339827-1	A	BENCH & LEADMAKER	MECH POST FEED	HDI APPLICATOR
7-1339827-1	A	BENCH & LEADMAKER	MECH POST FEED	-1 AND SPARE PARTS
7-1339827-7	A	-	-	SPARE PARTS KIT

SET UP GAGE		REVISONS	
LOC	DISP	DATE	BY
A	66	23APR2008	LJL
A		SEE ECO-08-010108	MC

CRIMP DATA ESCUBEDO TERMINAL ESCUBEDO CRIMP SPECS

TERMINAL NAME: RECEPTACLE SERIES 6.3 TP

CRIMP	SIZE	TYPE	RANGE
WIRE	2.97 [.117 IN]	F	1.00-2.50mm ²
INSUL	4.06 [.160 IN]	F	3.00-4.30 [.118-.169 IN]

WIRE STRIP LENGTH 5.00-6.00 [.197-.236 IN] APPL INSTRUCTIONS 408-8323

TERMINAL APPL SPEC	ESCUBEDO DATA SHT	FEED
4832.24	-	21.40 [.843 IN]

TERMINALS APPLIED

TE TERM PN	MANUF TERM PN	TE TERM PN	MANUF TERM PN
1949640-1	4832.00	1949640-7	4832.32
1949640-2	4832.01	1949640-8	4832.70
1949640-3	4832.02	1949640-9	4832.50
1949640-4	4832.24	1-1949640-0	4832.51
1949640-5	4832.30	1-1949640-1	4832.52
1949640-6	4832.31		

WIRE SIZE	CRIMP HEIGHT	PIN PN & LENGTH [IN]
2.50mm ²	2.16 ±0.05 [.085 ±.002 IN]	5-354778-5 [.2770]
2.00mm ²	2.06 ±0.05 [.081 ±.002 IN]	6-354778-1 [.2800]
1.50mm ²	1.99 ±0.05 [.078 ±.002 IN]	6-354778-5 [.2820]
1.00mm ²	1.78 ±0.05 [.070 ±.002 IN]	8-354778-1 [.2900]

- 1 RECOMMENDED SPARE PARTS
- 2. GREASE RAM, CAM, CAM FOLLOWER AND FEED ROD LIGHTLY.
- 3 CERTAIN TERMINALS REQUIRE LUBRICATION. REFER TO THE APPLICATOR INSTRUCTION SHEET FOR MORE INFORMATION.
- 4. LUBRICATE DAILY PER THE APPLICATOR INSTRUCTION SHEET SUPPLIED WITH THE APPLICATOR.
- 5 CRIMP DATA SUPPLIED BY THE TERMINAL MANUFACTURE.
- 6 WIRE AND INSULATION RANGES ARE THAT OF THE TERMINAL.
- 7 CUT TO LENGTH AT ASSEMBLY.

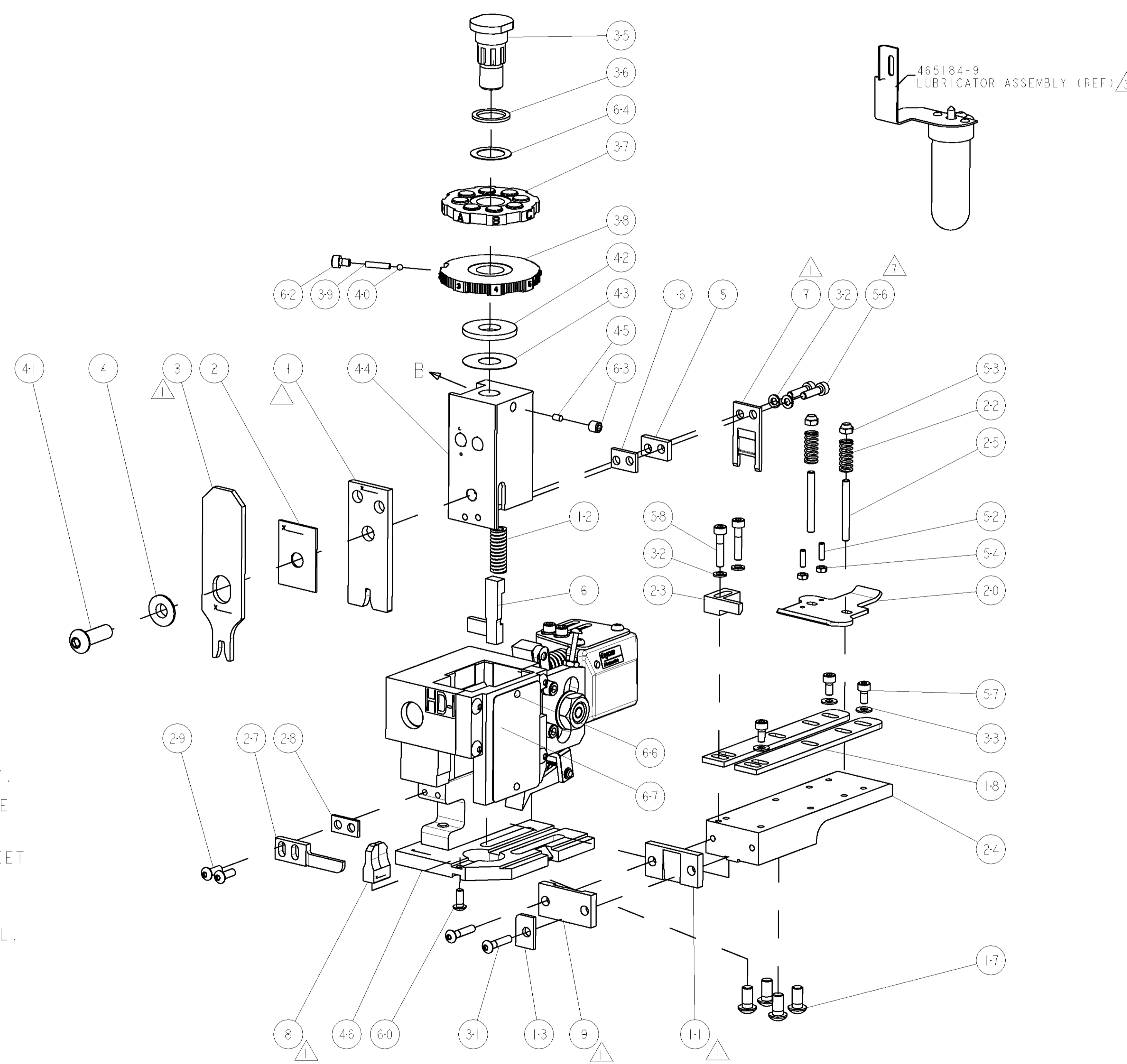
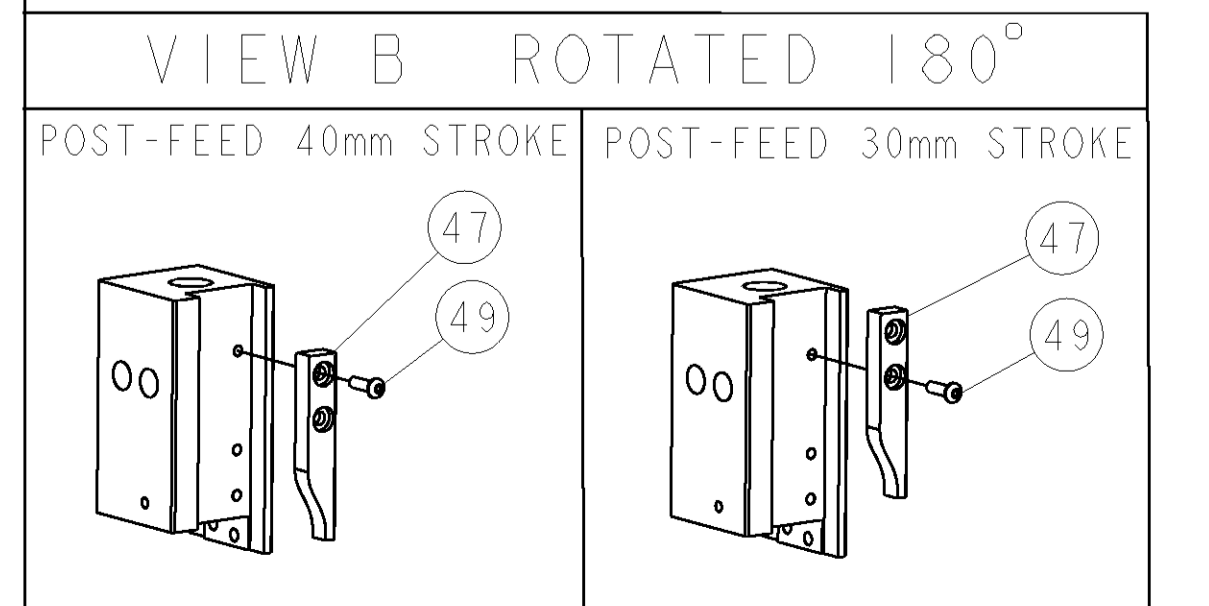

-	1	1	1338705-2	DOCUMENTATION PACKAGE	71
-	1	1	461264-1	PLATE, IDENTIFICATION	67
-	2	2	21017-2	SCREW, DRIVE	66
-	1	1	986950-1	WASHER, FLAT PRECISION	64
-	1	1	3-18031-0	SCR, SET, CUP POINT M6 X 6.0	63
-	1	1	18023-9	SCR, SKT HD CAP M4 X 6.0	62
-	1	1	18024-7	SCR, BTN SKT HD CAP (M4 X 10.0)	60
-	2	2	1-18023-4	SCR, SKT HD CAP M4 X 20.0	58
-	3	3	1-18023-0	SCR, SKT HD CAP M4 X 8.0	57
-	2	2	1-18023-3	SCR, SKT HD CAP M4 X 16.0	56
-	2	2	18029-1	NUT, HEX, REG M3	54
-	2	2	986965-1	NUT, LOCK, HEX, TORQUE (M4)	53
-	2	2	2-18032-2	SCR, SET, FLT POINT M3 X 10.0	52
-	1	1	18024-3	SCR, BTN SKT HD CAP (M3 X 10.0)	49
-	1	1	1338676-1	CAM, UNIVERSAL POST-FEED	47
-	1	1	1338662-1	SUB ASSY, APPLICATOR FRAME	46
-	1	1	690191-1	PLUG, NYLON	45
-	1	1	1320998-1	RAM	44
-	1	1	690125-1	SHIM SUB-ASSY	43
-	1	1	690124-1	WASHER, RAM (.115)	42
-	1	1	2-18024-6	SCR, BTN SKT HD CAP (M8 X 25.0)	41
-	1	1	23241-1	BALL, STEEL	40
-	1	1	2-22278-7	SPRING, COMPRESSION	39
-	1	1	1320922-1	DISC, ADJUST, INSULATION CRIMP	38
-	1	1	354777-1	WIRE DISC, ASSEMBLY	37
-	1	1	22480-5	SPRING, COMPRESSION	36
-	1	1	690212-1	POST, RAM	35
-	3	3	18027-2	WASHER, FLAT, REG M4	33
-	4	4	18025-2	WASHER, SPRG LOCK, REG M4	32
-	2	2	1-18024-0	SCR, BTN SKT HD CAP (M4 X 20.0)	31
-	2	2	18024-8	SCR, BTN SKT HD CAP (M4 X 12.0)	29
-	1	1	3-690451-2	SPACER, STRIPPER	28
-	1	1	240639-1	STRIPPER (MACHINING)	27
-	2	2	1320906-1	STUD, THREADED	25
-	1	1	1320995-1	PLATE, STRIP GUIDE	24
-	1	1	240825-1	PLATE, STRIP HOLD DOWN	23
-	2	2	4-22281-1	SPRING, DRAG	22
-	1	1	1338665-1	DRAG	20
-	2	2	1338663-6	GUIDE, LOWER STRIP	18
-	4	4	1-18024-8	SCR, BTN SKT HD CAP (M6 X 12.0)	17
-	1	1	1338708-1	SPACER, SLUG BLADE	16
-	1	1	690481-3	SPACER, HOLD DOWN	13
-	1	1	23846-1	SPRING, DIE	12
-	1	1	240644-9	PLATE, REAR SHEAR	11
-	-	-	-	-	10
-	1	1	5-690482-9	PLATE, FRONT SHEAR	9
-	1	2	3-1633384-9	ANVIL, COMBINATION	8
-	1	1	690474-3	BLADE, SLUG	7
-	1	1	3-455892-2	HOLD DOWN, TERMINAL	6
-	1	1	2-240641-4	SPACER	5
-	1	1	238009-1	BLOCK, FL CRIMPER SPACER	4
-	1	2	9-1213077-4	CRIMPER, INSULATION PREMIUM	3
-	1	1	1-455888-0	SPACER, CRIMPER	2
-	1	2	2-1633588-2	CRIMPER, WIRE	1
-	77	-71	-1	PART NO	
-	-	-	-	DESCRIPTION	
-	-	-	-	ITEM NO	

THIS DRAWING IS UNPUBLISHED. RELEASED FOR PUBLICATION. ALL RIGHTS RESERVED.

DIMENSIONS: INCHES	TOLERANCES UNLESS OTHERWISE SPECIFIED:	DRAWN: L. LOFTHOUSE	DATE: 28FEB2008
9 PLC ±.01	1 PLC ±.01	CHK: M. CLIFFORD	DATE: 28FEB2008
5 PLC ±.001	4 PLC ±.0001	NAME: Tyco Electronics	Address: Harrisburg, PA 17105-3608
ANGLES ±.0001	FINISH	PRODUCT SPEC: END FEED HDI APPLICATOR	
MATERIAL	FINISH	APPLICATION SPEC	
WEIGHT	SCALE: 3:5	SIZE: A	CAGE CODE: 00779
CUSTOMER DRAWING	SCALE: 3:5	SHEET: 1	REV: A