

- NOTE 1 LEAD CO-PLANARITY IS 0.1mm MAX.
- ② CONTACTS ARE 3 STEPS SEQUENTIAL. (MF CONTACT A->SIGNAL CONTACT->MF CONTACT B) WHEN USING THIS SEQUENTIAL STRUCTURE, PLEASE AVOID ANGLED INSERTION.
 - ③ MF CONTACT A AND MF CONTACT B CAN BE USED AS POWER SUPPLY CONTACT. (3A/PIN MAX)
 - ④ IT SHOWS THE VACUUM PICKUP AREA. (SEE PAGE 2)
REMOVE THE MYLAR TAPE BEFORE MATING CONNECTORS.
 - ⑤ THIS IS PACKAGED IN TRAY. (40pcs/TRAY)
 - ⑥ BLEMISH AND HIT MARK CAN BE OCCURED THROUGH OUT THE MANUFACTURING PROCESS WHICH DOESN' T AFFECT QUALITY LEVEL.
 - ⑦ THE DIMENSIONS IN PARENTHESES ARE FOR REFERENCES.

NO.	MATERIAL	FINISH	REMARKS	NO.	MATERIAL	FINISH	REMARKS
3	PHOSPHOR BRONZE		CONTACT AREA:GOLD 0.1 μm LEAD AREA:GOLD 0.03 μm UNDER PLATING:NICKEL 1.3 μm	5	COPPER ALLOY		CONTACT AREA:GOLD 0.1 μm LEAD AREA:TIN-PLATING 1 μm UNDER PLATING:NICKEL 1.3 μm
2	POLYAMIDE	BLACK	UL94V-0	4	COPPER ALLOY		CONTACT AREA:GOLD 0.1 μm LEAD AREA:TIN-PLATING 1 μm UNDER PLATING:NICKEL 1.3 μm
1	POLYAMIDE	BLACK	UL94V-0				

UNITS	SCALE	COUNT	DESCRIPTION OF REVISIONS	DESIGNED	CHECKED	DATE
mm	2 : 1	△	APPROVED : HS. OKAWA 12.06.12 CHECKED : KI. HIROKAWA 12.06.12 DESIGNED : AH. EDASHIGE 12.06.12 DRAWN : AH. EDASHIGE 12.06.12			

DRAWING NO.	PART NO.	CODE NO.
EDC3-343465-00	FX18-100S-0.8SV15	CL579-0036-7-00

Apr.1.2017 Copyright 2017 HIROSE ELECTRIC CO., LTD. All Rights Reserved.

RECOMMENDED LAND PATTERN DIMENSION OF PCB(2:1)
 (PCB THICKNESS:t=1.6mm METAL MASK THICKNESS:t=0.12mm)

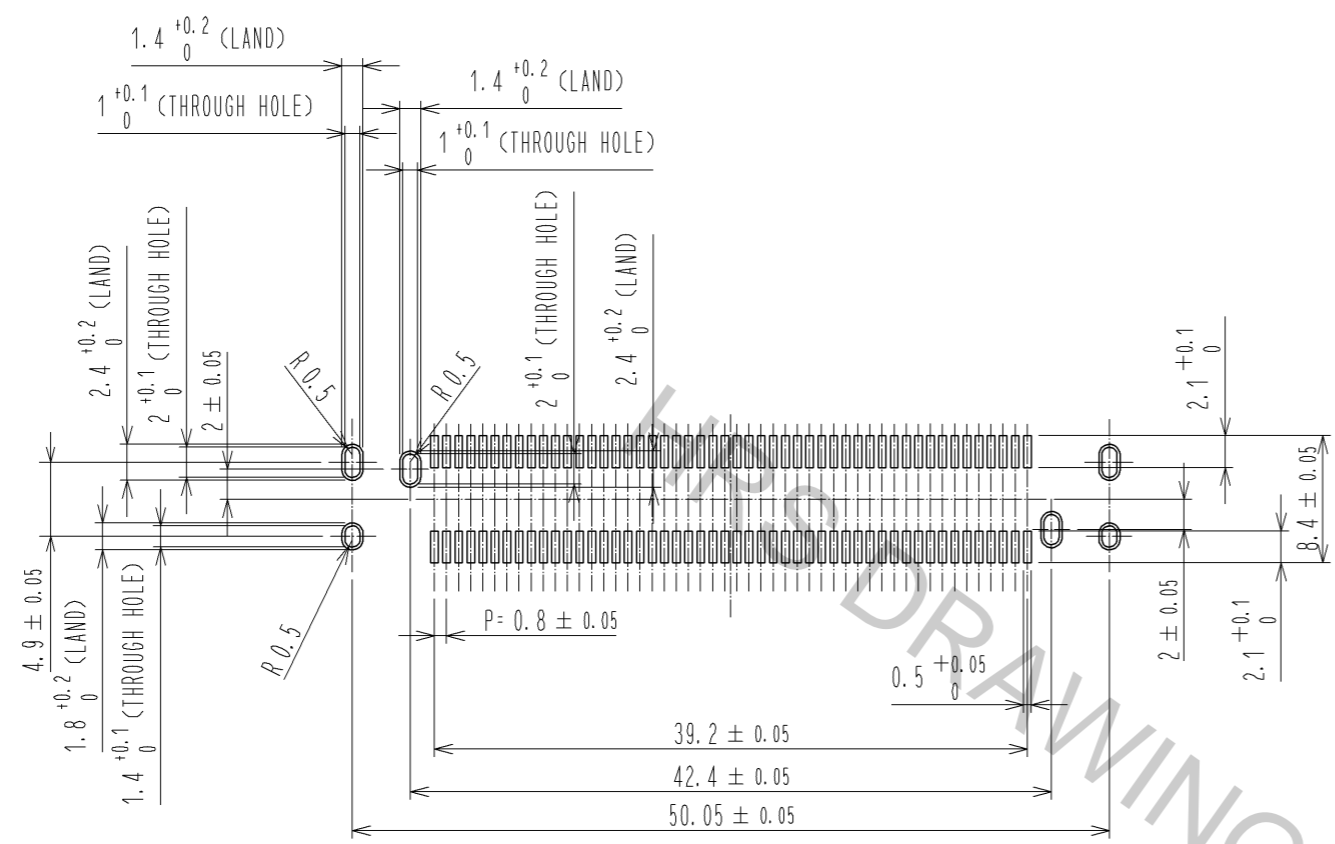

8 CONFIGURATION OF MF CONTACT A

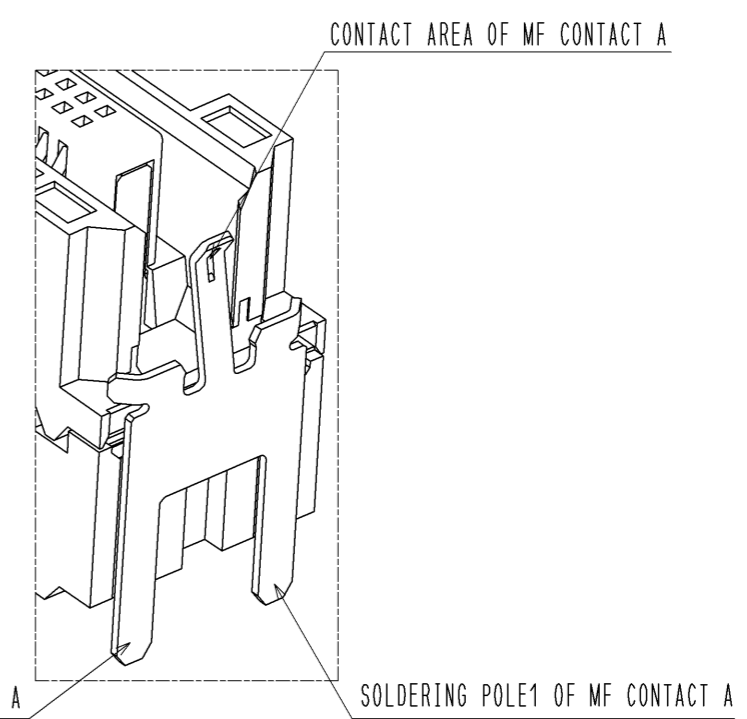

NOTE 8 SOLDERING LEAD OF MF CONTACT A SPLITS INTO TWO POLES.
 BE SURE TO CONNECT TO THE SAME CIRCUIT.

5 DRAWING FOR PACKING(1:2)

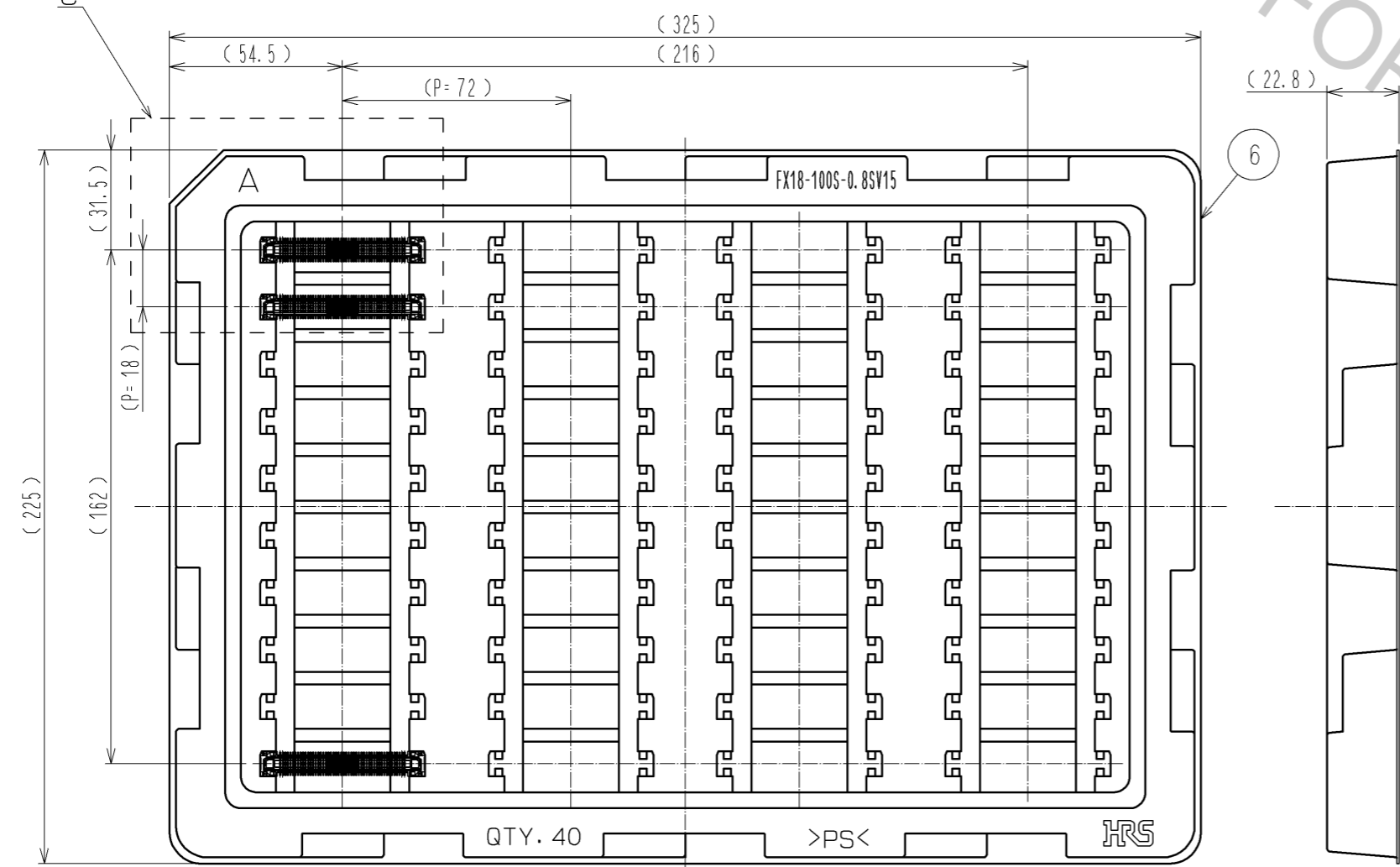

C (1:1)

FX18-100S-0.8SV15

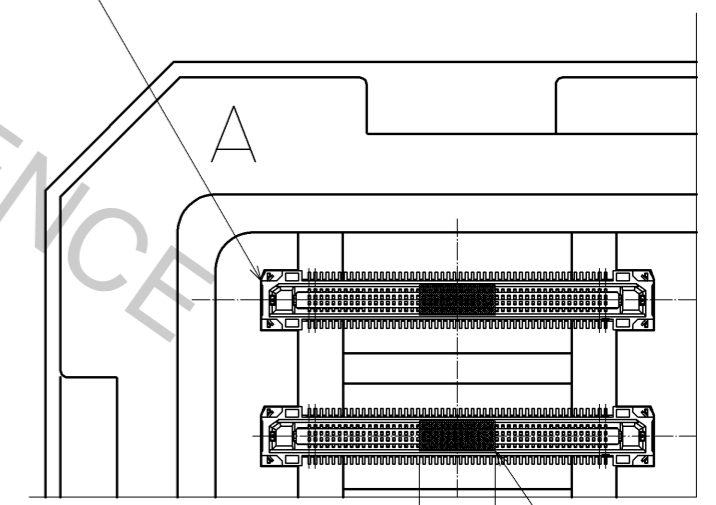

HRS	DRAWING NO.	EDC3-343465-00	2/2
	PART NO.	FX18-100S-0.8SV15	
	CODE NO.	CL579-0036-7-00	