

# 2000 - SERIES

## ASSEMBLY INSTRUCTIONS FOR PRINTER & PAPER STAND

BUL10185  
REV. B  
PAGE 1 OF 1

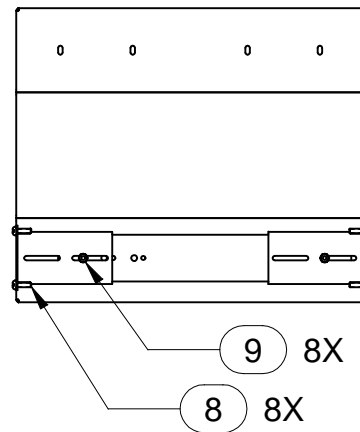
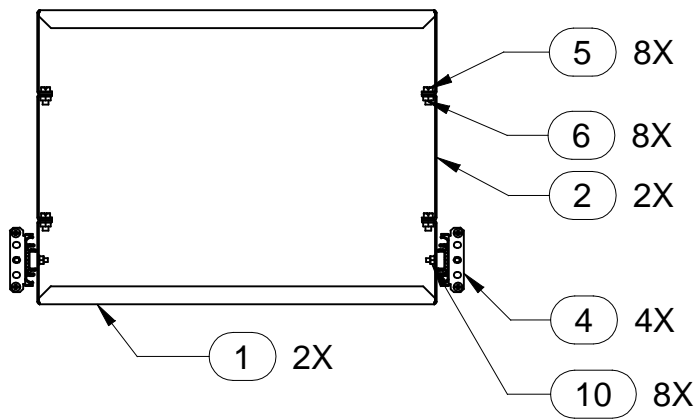
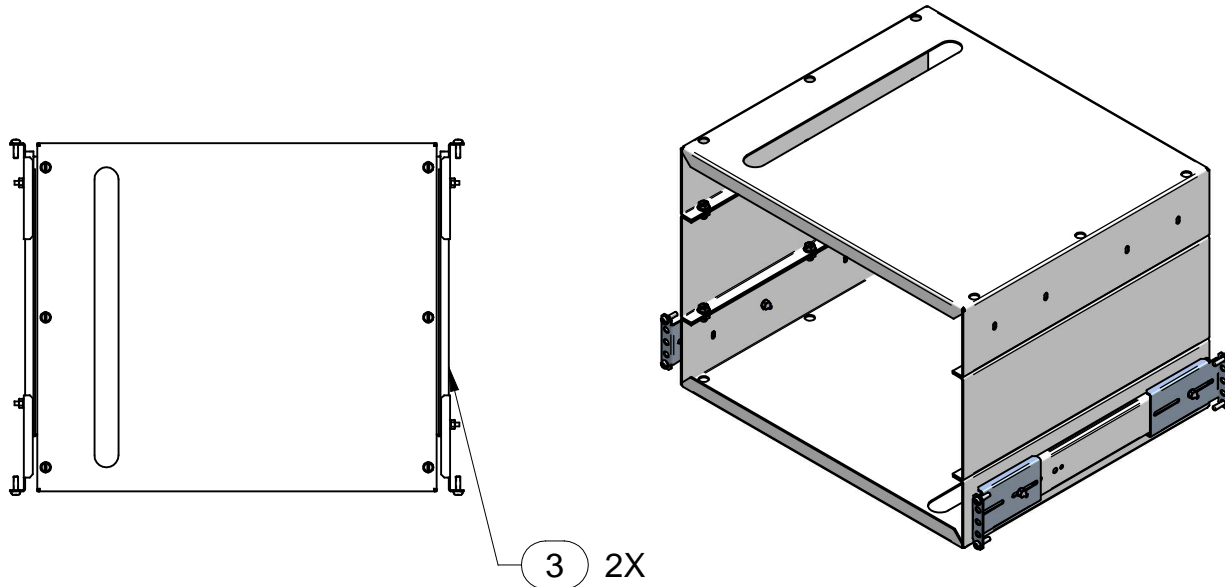

PART #	QTY	DESCRIPTION
1	2	TOP & BOTTOM
2	2	CENTER SPACER (2CHPS ONLY)
3	2	BALL BEARING SLIDES
4	4	SLIDE BRKTS
5	8	1/4 - 20 CAP SCREWS
6	8	1/4 - 20 KEP NUT
7	8	10-32 CLIP NUTS (NOT SHOWN)
8	8	10-32 SCREW
9	8	8-32 SCREW
10	8	8-32 KEP NUT

A) ASSEMBLE (PART 1) TOP AND BOTTOM TOGETHER USING 1/4-20 HARDWARE (PART 5&6). FOR 2CHPS USE CENTER SPACER BETWEEN TOP AND BOTTOM (PART2) ON EACH SIDE.

B) FASTEN INNER PART OF SLIDE TO BOTTOM OF ASSEMBLED PRINTER UNIT USING 8-32 HARDWARE (PARTS 9 & 10).

C) ADJUST SLIDE BRACKETS (PART 4) TO SUIT DISTANCE BETWEEN COMBINATION RAILS. TO ADJUST LOOSEN 8-32 SCREWS SLIDE TO ADJUST THEN RETIGHTEN SCREWS.

D) MOUNT OUTER SLIDES TO COMBINATION RAILS USING 10-32 HARDWARE MAKING SURE SLIDES ARE AT THE SAME HEIGHT. INSTALL PRINTER STAND UNIT INTO SLIDES PUSH BACK INTO THE CLOSED POSITION.

### TOOL BOX



#2 Phillips  
Screw Driver



3/8 or 7/16 Open  
End  
Wrench



Tape  
Measure



**HAMMOND  
MANUFACTURING™  
D A T A C O M**