

Messrs:

Preliminary Specification

Customer part number	
Customer specification Number	
Product	Tuning Fork Crystal
Model	ST3215SB
Frequency	32.768 kHz
Product code	ST3215SB32768H5HPWAA

Pb Free, RoHS Compliant

[STAMP]

Sales office

KYOCERA Corporation
 (Electronic Components Sales Division)
 Head Office 6 Takeda Tobadono-cho, Fushimi-ku,
 Kyoto 612-8501 Japan
 TEL 075-604-3500
 FAX 075-604-3501

Production

KYOCERA KINSEKI Corporation
 (Quartz Crystal Department)
 1-8-1, Izumi-honcho, Komae-Shi,
 Tokyo 201-8648 Japan
 TEL 03-5497-3111
 FAX 03-5497-3209

Design KYOCERA KINSEKI Co. Yohkaichi Plant Quartz Crystal division	Drawn by F.Fujisaki	Checked by M.Ishibashi	Approved by S.Itoh
------------------------------------------------------------------------------------	--------------------------------------	-----------------------------------------	-------------------------------------

No.	EQM08-5GC-T030881-00
-----	----------------------

Date:2008/12/08

Change History

REV	DESCRIPTION	DATE	DRAWN	CHECKED	APPROVED
00	First issue		F.Fujisaki	M. Ishibashi	S. Itoh

1. APPLICATION

This specification sheet is applied to tuning fork crystal "ST3215SB".

2. PART NUMBER

ST3215SB32768H5HPWAA

3. RATINGS

Items	SYMB.	Rating	Unit
Operating Temperature	Topr	-40~+85	deg. C
Storage Temperature range	Tstg	-45~+85	deg. C

4. CHARACTERISTICS**4-1 ELECTRICAL CHARACTERISTICS**

Item	Symbol	Electrical Specification				Unit
		Condition	Min	Typ.	Max	
Nominal Frequency	fo	Ta = 25 deg. C		32.768		kHz
Frequency Tolerance	df/fo	Ta = 25 deg.C	-20		20	ppm
Load Capacitance	CL			12.5		pF
Equivalent series resistance	R1	Ta= -30...85 deg.C			70	kΩ
Q-Value	Q		13000			
Motional capacitance	C1		3.0	3.7	4.4	fF
Shunt capacitance	Co		0.6	0.9	1.2	pF
Turning point	Tp		20	25	30	deg. C
Secondary temperature Coefficient	K		-4.0	-3.6		10 ⁻⁸ /degC ²
Aging	df/F	Ta = 25 deg. C	-3	0	3	ppm/year
Drive level	DL			0.1	0.5	μW
Insulation resistance (between electrodes)	IR	Ta = -30 ... 85 deg. C	500			MΩ

4-2 MOISTURE SENSITIVITY LEVEL

Level 2

7. TAPING

7.1 TAPING

Maximum quantity per 1 reel is Max 10,000pcs(ø330 Reel) and oriented part in 1 direction

1. Material of the carrier tape shall be polystyrene or A-PET (ESD).
2. Material of the seal tape shall be polyester (ESD).
3. The seal tape shall not cover the sprocket holes and not protrude from the carrier tape.
4. The R of the corner without designation is 0.2R MAX.
5. Misalignment between centers of the cavity and a sprocket hole shall be 0.05mm or less.
6. Cumulative pitch tolerance of "G" shall be $\pm 0.2\text{mm}$ at 10 pitches.
7. The directivity of printing in an embossing tape shall be unified as shown in the above-mentioned figure.
8. Peeling force of the seal tape is in the range of 0.1 to 0.7N.

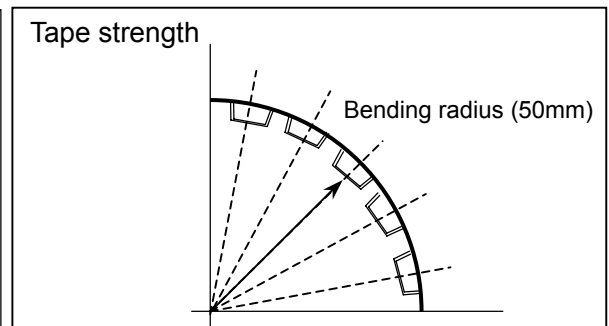
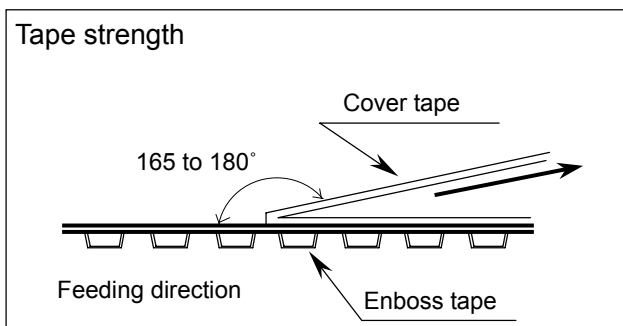
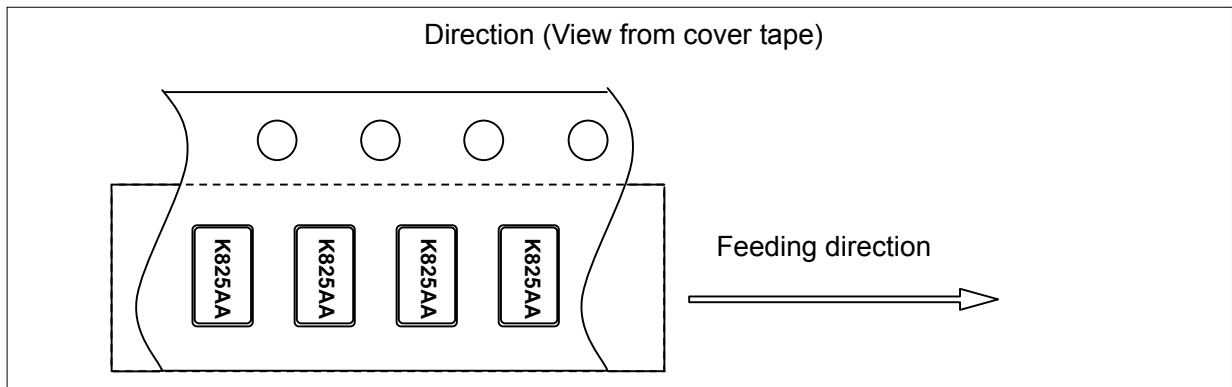
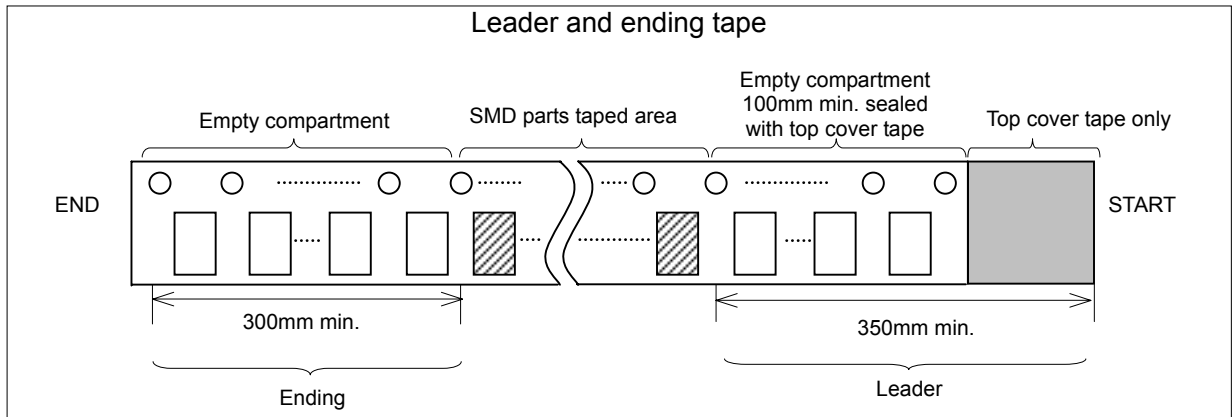

7-2 Emboss Taping specifications

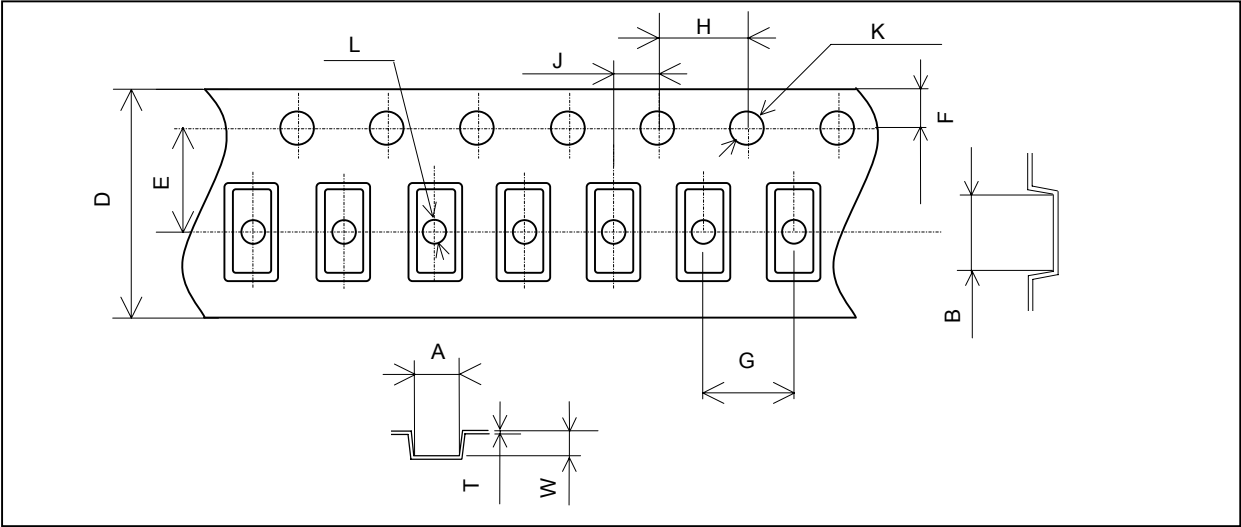

symbol	A	B	D	E	F	G
Dimension	1.8±0.1	3.6±0.1	12.0±0.3	5.5±0.1	1.75±0.1	4.0±0.1
Symbol	H	J	K	L	W	T
Dimension	4.0±0.1	2.0±0.1	1.5+0.1/-0	1.0(min)	1.0±0.1	0.3±0.05

(Unit: mm)

7-3 Reel specifications

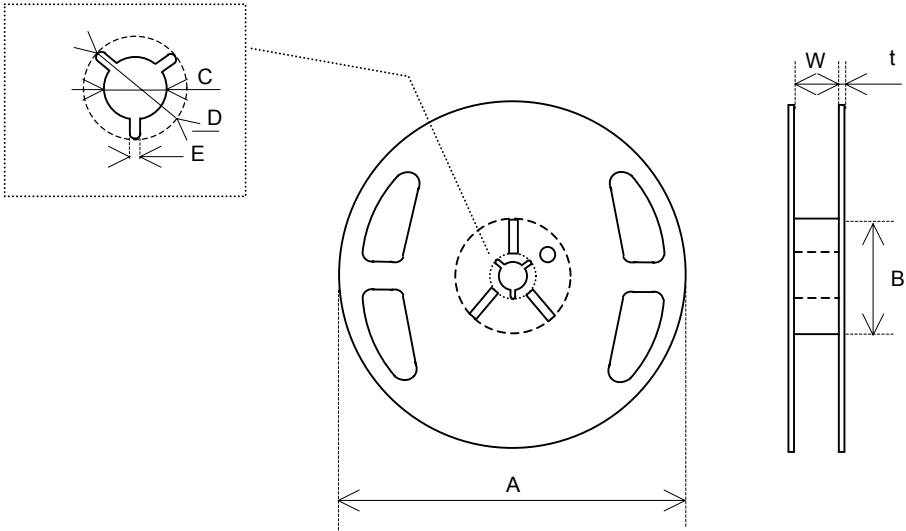

Symbol	A	B	C	D
Dimension	Φ330±0.2	Φ100±1.0	Φ13±0.2	Φ21±0.8
Symbol	E	W	t	
Dimension	2.0±0.5	13.5±1	2.0±0.5	

(Unit: mm)

8. RELIABILITY

Frequency Stability and ESR Stability After stressing.

TEST ITEM		Frequency Stability (ppm)	ESR Stability (%)	Remarks
8.1	Low temp. use/storage	± 5	± 30	Ta=25 deg. C
8.2	High temp. use/storage	± 5		
8.3	Shock	± 20		
8.4	Vibration sinusoidal	± 5		
8.5	Vibration random	± 5		
8.6	Soldering iron resistance	± 5		
8.7	Manual hot gas resistance	± 10		
8.8	High temp. With humidity	± 5		
8.9	Temperature cycle	± 5		

9. REFLOW PROFILE

Pb-free reflow requirements for soldering heat resistance

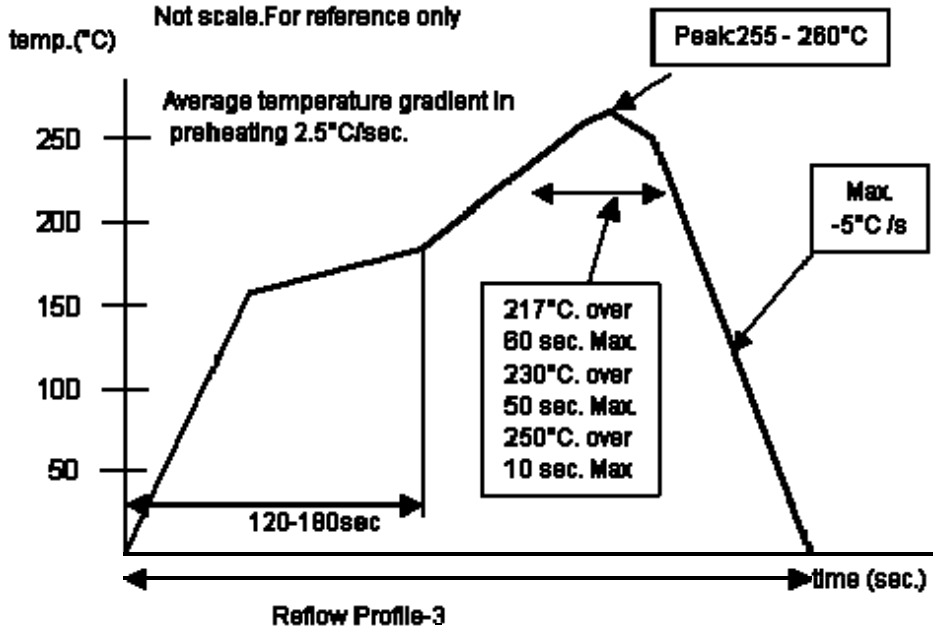

10.LOT CALENDAR

WEEK	MONTH	SUN	MON	TUE	WED	THU	FRI	SAT	WEEK	MONTH	SUN	MON	TUE	WED	THU	FRI	SAT
901	1					1	2	3	928	7	5	6	7	8	9	10	11
902		4	5	6	7	8	9	10	929		12	13	14	15	16	17	18
903		11	12	13	14	15	16	17	930		19	20	21	22	23	24	25
904		18	19	20	21	22	23	24	931		26	27	28	29	30	31	1
905		25	26	27	28	29	30	31	932		8	2	3	4	5	6	7
906	2	1	2	3	4	5	6	7	933	9		10	11	12	13	14	15
907		8	9	10	11	12	13	14	934	16		17	18	19	20	21	22
908		15	16	17	18	19	20	21	935	23		24	25	26	27	28	29
909		22	23	24	25	26	27	28	936	30		31	1	2	3	4	5
910	3	1	2	3	4	5	6	7	937	9	6	7	8	9	10	11	12
911		8	9	10	11	12	13	14	938		13	14	15	16	17	18	19
912		15	16	17	18	19	20	21	939		20	21	22	23	24	25	26
913		22	23	24	25	26	27	28	940		27	28	29	30	1	2	3
914	4	29	30	31	1	2	3	4	941	10	4	5	6	7	8	9	10
915		5	6	7	8	9	10	11	942		11	12	13	14	15	16	17
916		12	13	14	15	16	17	18	943		18	19	20	21	22	23	24
917		19	20	21	22	23	24	25	944		25	26	27	28	29	30	31
918		26	27	28	29	30	1	2	945		11	1	2	3	4	5	6
919	5	3	4	5	6	7	8	9	946	8		9	10	11	12	13	14
920		10	11	12	13	14	15	16	947	15		16	17	18	19	20	21
921		17	18	19	20	21	22	23	948	22		23	24	25	26	27	28
922	24	25	26	27	28	29	30	949	29	30		1	2	3	4	5	
923	6	31	1	2	3	4	5	6	950	12	6	7	8	9	10	11	12
924		7	8	9	10	11	12	13	951		13	14	15	16	17	18	19
925		14	15	16	17	18	19	20	952		20	21	22	23	24	25	26
926		21	22	23	24	25	26	27	953		27	28	29	30	31		
927		28	29	30	1	2	3	4									