

Using the 1.0 MHz Dual Switch-Mode DDR Power Supply (KIT34716EPEVBE)

1 Introduction

This User's Guide will help the designer get better acquainted with the 34716 IC and Evaluation board. It contains a procedure to configure each block of the 34716 in a practical way, which is based on a working Evaluation Board designed by Freescale (KIT34716EPEVBE).

2 34716 Specification

The 34716 is a highly integrated, space-efficient, low cost, dual synchronous buck switching regulator with integrated N-channel power MOSFETs. It is a high performance point-of-load (PoL) power supply with its second output having the ability to track an external reference voltage. It provides a full power supply solution for Double-Data-Rate (DDR) Memories.

Channel one provides a source only 5.0 A drive capability, while channel two can sink and source up to 3.0 A. Both channels are highly efficient with tight output regulation. With its high current drive capability, channel one can be used to supply the V_{DDQ} to the memory chipset. The second channel's

Contents

1 Introduction	1
2 34716 Specification	1
3 Application Diagram	2
4 Board's Specifications	2
5 Component Selection for 34716 Eval Board.	3
6 Layout Design	12
7 Conclusion	16
8 References	16

5 Component Selection for 34716 Eval Board

5.1 I/O Parameters:

$$V_{IN} = P_{VIN1} = 3.3V$$

$$FSW = 1 \text{ MHz}$$

$$V_{OUT1} = V_{DDQ} = 1.8 \text{ V (DDR2 Standard)}$$

$$I_{OUT1} = 5 \text{ A}$$

$$P_{VIN2} = V_{REFIN} = V_{OUT1} = 1.8V$$

$$V_{OUT2} = V_{TT} = 0.90 \text{ V}$$

$$I_{OUT2} = 3A$$

5.2 Configuring the Output Voltage:

Channel 1 of the 34716 is a general purpose DC-DC converter, the resistor divider to the -INV1 node is the responsible for setting the output voltage. The equation is:

$$V_{OUT} = V_{REF} \left(\frac{R1}{R2} + 1 \right)$$

Where V_{REF} is the internal $V_{BG} = 0.7V$.

Then, for a regulated output at 1.8 V, we choose $R1 = 20K\Omega$ and $R2$ is calculated as follows:

$$R2 = \frac{V_{REF} R1}{V_{OUT} - V_{REF}} = 12.72K\Omega$$

Channel 2 is a DDR specific voltage power supply, and the output voltage is given by the equation:

$$V_{TT} = \frac{V_{REFIN}}{2}$$

Where V_{REFIN} is the V_{DDQ} voltage supplied by V_{OUT1} .

5.3 Switching Frequency Configuration

The switching frequency will have a value of 1.0 MHz by connecting the FREQ terminal to the GND terminal. If the smallest frequency value of 200 KHz is desired, then connect the FREQ terminal to VDDI. To program the switching frequency to another value, an external resistor divider will be connected to the FREQ terminal to achieve the voltages given by the [Frequency Selection Table](#)

Frequency Khz	Voltage applied to pin FREQ [V]
200	2.341 – 2.500
253	2.185 - 2.340
307	2.029 - 2.184
360	1.873 - 2.028
413	1.717 – 1.872
466	1.561 – 1.716
520	1.405 - 1.560
573	1.249 - 1.404
627	1.093 - 1.248
680	0.936 - 1.092
733	0.781 - 0.936
787	0.625 - 0.780
840	0.469 - 0.624
893	0.313 - 0.468
947	0.157 - 0.312
1000	0.000 - 0.156

Table 1. Frequency Selection Table

The EVB frequency is set to 1 MHz, connecting the FREQ terminal directly to GND.

5.4 Selecting Inductor

Inductor calculation is as follows:

$$L = D'_{MAX} * T * \frac{(V_{OUT} + I_{OUT} * (R_{ds(on)}_{ls} + r_{w}))}{\Delta I_{OUT}}$$

$$D'_{MAX} = 1 - \frac{V_{OUT}}{V_{in_max}}$$

Maximum Off time percentage

$$T = 1\mu s$$

Switching period

$$R_{ds(on)}_{ls} = 45m\Omega$$

Drain – to – source resistance of FET

$$r_{w} = 10m\Omega$$

Winding resistance of Inductor

$$\Delta I_{OUT} = 0.4 * I_{OUT}$$

Output current ripple

$$L1 = 0.72\mu H$$

$$L2 = 0.75\mu H$$

However, since channel 1 will be serving as power supply for channel 2, we have to locate the LC poles at different frequencies in order to ensure that the input impedance of the second converter is always higher than the output impedance of the first converter, and thus, ensure system stability. To move the LC poles, we can select different values of “L” for each channel, for instance, L1 = 1.0μH and L2 = 1.5μH, to allow some operating margin for each channel.

5.5 Input Capacitors for PVIN1 and PVIN2

Input capacitor selection process is the same for both channels, and should be based on the current ripple allowed on the input line, since output of channel 1 is the input of channel 2, the input capacitor on channel 2 should be calculated for the maximum allowed output ripple on channel 1. The input capacitor should provide the ripple current generated during the inductor charge time. This ripple is dependent on the output current sourced by 34716 so that:

$$I_{RMS} = I_{OUT} \sqrt{D(1-D)}$$

Where:

I_{RMS} is the RMS value of the input capacitor current.

I_{OUT} is the output current,

$D = V_{OUT}/V_{in}$ is the duty cycle.

For a buck converter, I_{RMS} has its maximum at $PVIN = 2V_{OUT}$

Since

$$I_{RMS_MAX} = \sqrt{\frac{P_{MAX}}{ESR}}$$

Where P_{MAX} is the maximum power dissipation of the capacitor and is a constant based on physical size (generally given in the datasheets under the heading AC power dissipation.). We derive that the lower the ESR, the higher would be the ripple current capability. In other words, a low ESR capacitor (i.e., with high ripple current capability) can withstand high ripple current levels without overheating.

Therefore, for greater efficiency and because the overall voltage ripple on the input line also depends on the input capacitor ESR, we recommend using low ESR capacitors.

$$C_{in_MIN} = \frac{0.5 * L * (I_{RMS})^2}{\Delta V_{OUT} * V_{in}}$$

For a $\Delta V_{OUT} = 0.5 * V_{in}$, Then $C_{in_MIN} = 30.4 \mu F$

To ensure better performance on regulation, an array of low ESR ceramic capacitors were used to get a total of 300 μF in both input terminals.

5.6 Selecting the Output Filter Capacitor

The following considerations are most important for the output capacitor and not the actual Farad value: the physical size, the ESR of the capacitor, and the voltage rating.

Calculate the minimum output capacitor using the following formula:

$$C_0 = \frac{\Delta I_{out}}{8 * F_{SW} * \Delta V_{out}}$$

A more significant calculation must include the transient response in order to calculate the real minimum capacitor value and assure a good performance.

Transient Response percentage	TR_%
Maximum Transient Voltage	TR_V_dip = V _{OUT} *TR_%
Maximum current step	$\Delta I_{out_step} = \frac{(V_{in_min} - V_{out}) * D_{max}}{F_{sw} * L}$
Inductor Current rise time	$dt_I_rise = \frac{T * I_{out}}{\Delta I_{out_step}}$
	$C_o = \frac{I_{out} * dt_I_rise}{TR_V_dip}$

To find the Maximum allowed ESR, the following formula was used:

$$ESR_{max} = \frac{\Delta V_{out} * F_{sw} * L}{V_{out}(1 - D_{min})}$$

As a DDR specification, the ESR should be around 2 mΩ. To achieve this, an array of capacitors in parallel were used, with 3 Low ESR Ceramic capacitors of 100 μF on each channel.

5.7 Bootstrap Capacitor

Freescale recommends a 0.1 μF capacitor for C_{BOOT1} and C_{BOOT2}.

5.8 Compensation Network

Compensation network is calculated exactly in the same way for both channels. Since we are using different values for L, the LC poles will be located at different frequencies to ensure stability of the system when converter 1 is supplying the power voltage of converter 2.

1. Choose a value for R1 (May be equal for both channels)
2. Using a Crossover frequency of 100 kHz, set the Zero pole frequency to F_{cross}/10

$$F_{p0} = \frac{1}{10} F_{cross} = \frac{1}{2\pi * R_1 C_F} \quad C_F = \frac{1}{2\pi * R_1 F_{p0}}$$

3. Knowing the LC frequency, the Frequency of Zero 1 and Zero 2 in the compensation network are equal to F_{LC}

$$F_{LC} = \frac{1}{2\pi \sqrt{L_X C_{O_X}}} = F_{Z1} = F_{Z2} \quad F_{Z1} = \frac{1}{2\pi * R_F C_F} \quad F_{Z2} = \frac{1}{2\pi * R_1 C_S}$$

$$R_F = \frac{1}{2\pi * C_F F_{Z1}} \quad C_S = \frac{1}{2\pi * R_1 F_{Z2}}$$

4. Calculate R_S by placing the first pole at the ESR zero frequency.

$$F_{ESR} = \frac{1}{2\pi * C_{Ox} * ESR} = F_{P1} \qquad F_{P1} = \frac{1}{2\pi * R_S C_S} \qquad R_S = \frac{1}{2\pi * F_{P1} C_S}$$

5. Set the second pole at Crossover Frequency to achieve a faster response and a proper phase margin.

$$F_{P2} = \frac{1}{2\pi * R_F * \frac{C_F C_X}{C_F + C_X}} \qquad C_X = \frac{C_F}{2\pi * R_F C_F F_{P2} - 1}$$

<p>For Channel 1</p> <p>FLC = 9.19 KHz</p> <p>$F_{ESR} = 265.26$ KHz (For ESR = 2.0mΩ)</p> <p>$F_{CROSS} = 100$ KHz</p> <p>$F_{PO} = 10$ KHz</p> <p>$R1 = 20$ KΩ</p> <p>$C_F = 0.75$ nF</p> <p>$R_F = 22$ KΩ</p> <p>$C_S = 0.91$ nF</p> <p>$R_S = 0.560$ KΩ</p> <p>$C_X = 0.015$ nF</p>
--

<p>For Channel 2</p> <p>FLC = 7.5 KHz</p> <p>$F_{ESR} = 265.26$ KHz (For ESR = 2.0mΩ)</p> <p>$F_{CROSS} = 100$ KHz</p> <p>$F_{PO} = 10$ KHz</p> <p>$R1 = 20$ KΩ</p> <p>$C_F = 1.8$ nF</p> <p>$R_F = 15$ KΩ</p> <p>$C_S = 1$ nF</p> <p>$R_S = 300$ KΩ</p> <p>$C_X = 0.020$ nF</p>

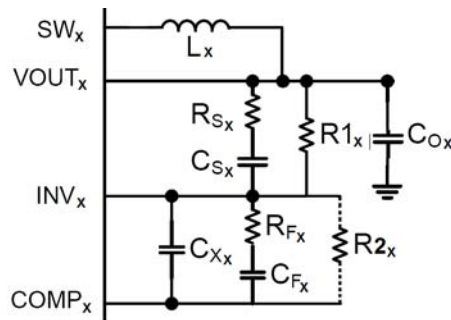

Figure 2. Compensation Network

Note: R2 only applies to Channel 1

5.9 Soft Start

[Table 2](#) shows the voltage that should be applied to the ILIM1 terminal to get the desired configuration of the soft start timing. Channel 2 of the 34716 has a soft start of 1.6ms.

Soft Start [ms]	Voltage applied to ILIM
3.2	1.25 - 1.49V
1.6	1.50 - 1.81V
0.8	1.82 - 2.13V
0.4	2.14 - 2.50V

Table 2. Soft Start Configurations

The ILIM1 terminal is directly connected to VDDI to achieve a soft start of 0.4ms.

5.10 Tracking Configurations

The 34716 allows a default Ratiometric tracking on channel 2 by connecting VDDQ on the VREFIN terminal. It has an internal resistor divider that allows an output of $VDDQ/2$.

5.11 EVB Schematic Design.

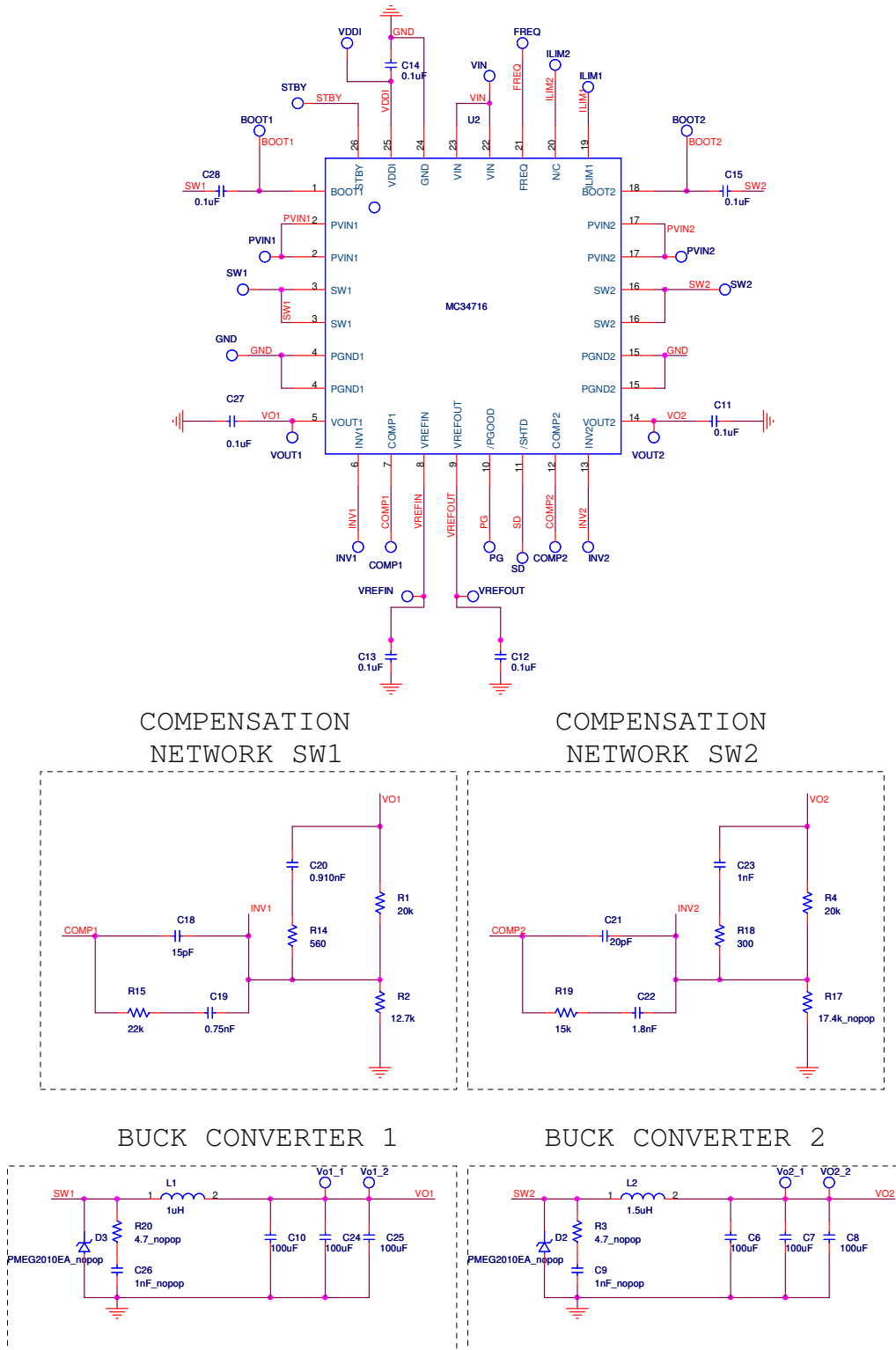
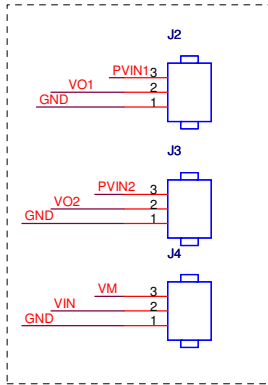
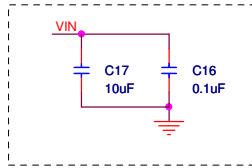

Figure 3. KIT34716EPEVBE Schematic Part 1

I/O SIGNALS



VIN CAPACITORS



PGOOD LED

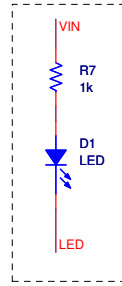

VMMASTER

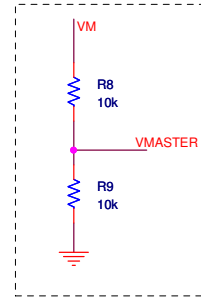

JUMPERS

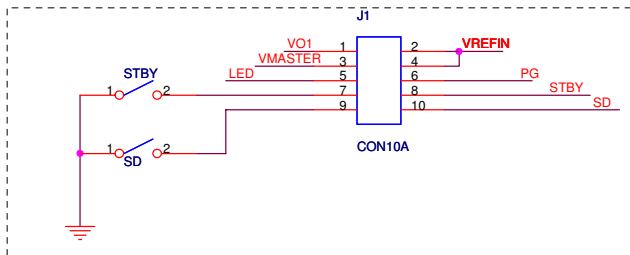

ILIM1, ILIM2, FREQ

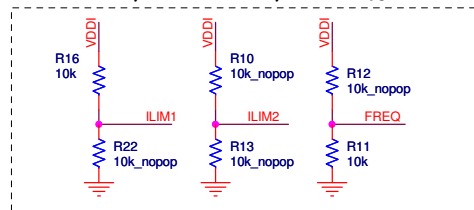

PVIN1 CAPACITORS

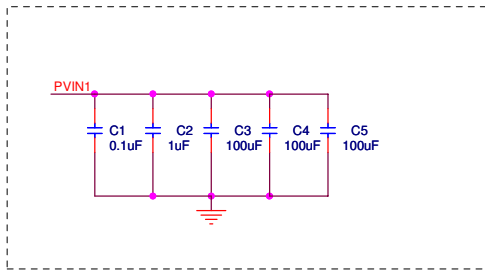

PVIN2 CAPACITORS

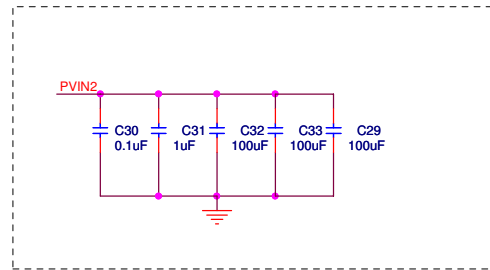

TRIMPOTS nopop

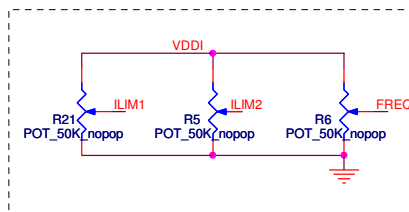

Figure 4. KIT34716EPEVBE Schematic Part 2

6 Layout Design

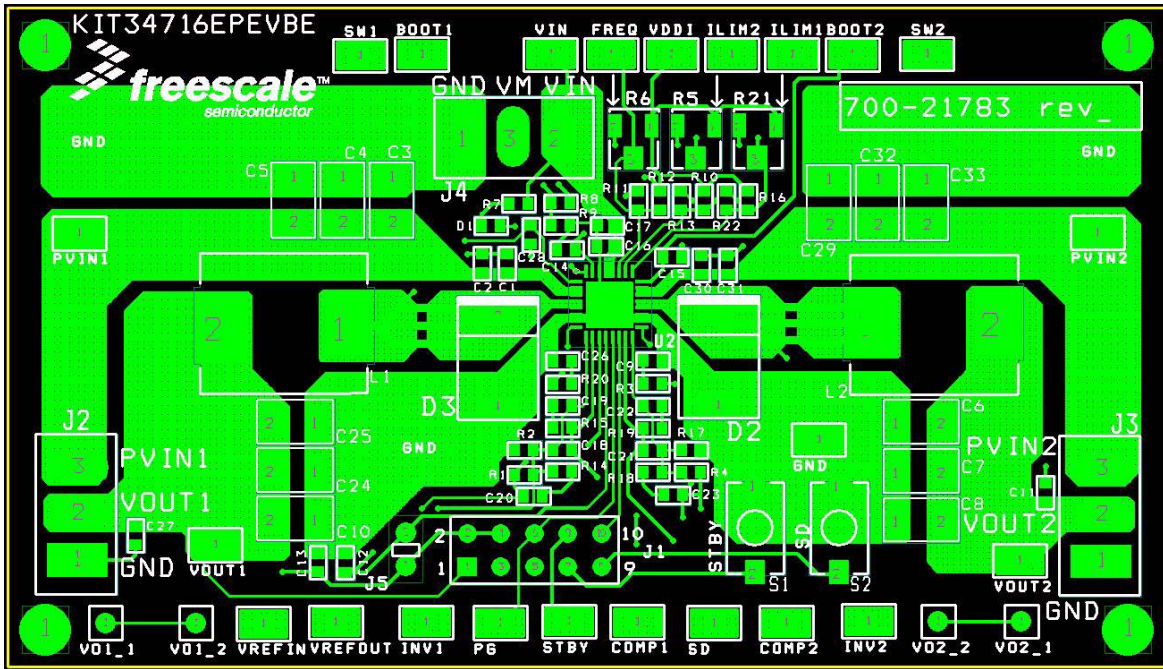

Figure 5. PCB Top View Layout Design

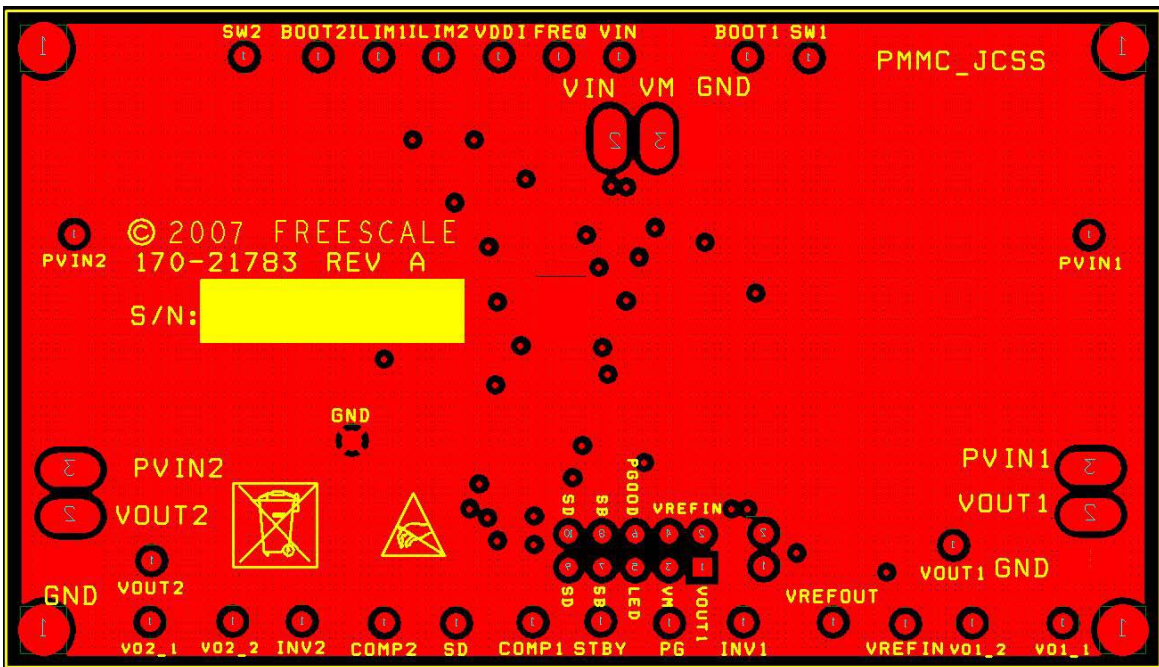

Figure 6. PCB Bottom View Layout Design

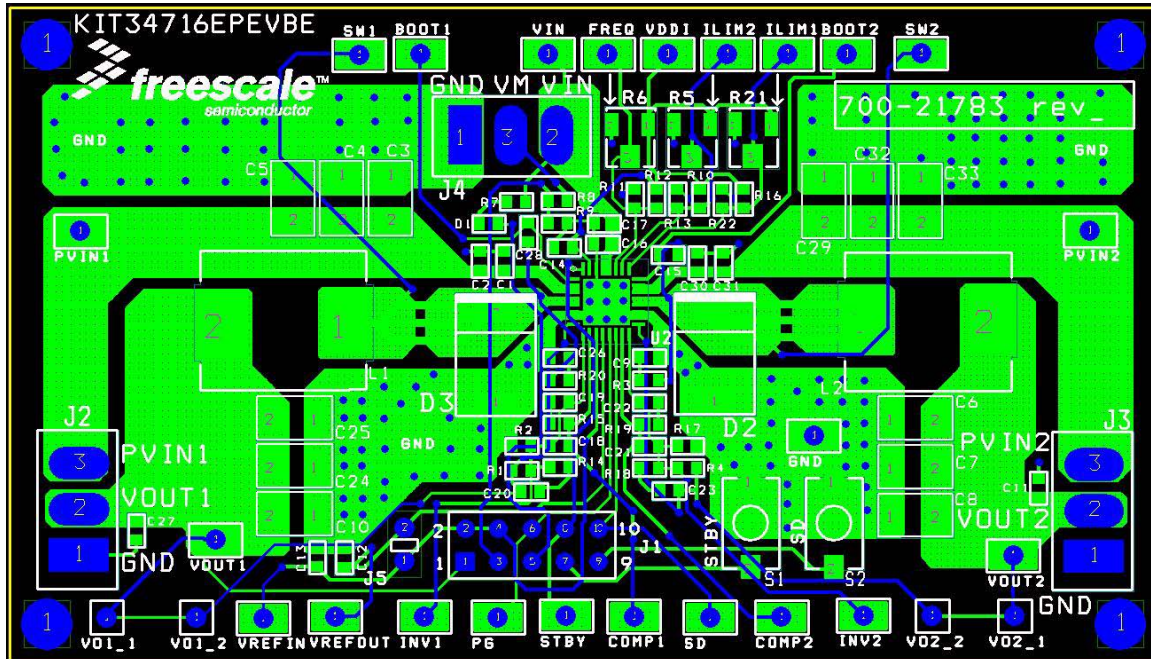

Figure 7. PCB Inner View Layout Design

6.1 PCB Layout Recommendations

- Place decoupling capacitors as close as possible to their corresponding pad(s)
- Try to place all components on just one Layer.
- Do not place a Ground Plane on component and routing side.
- Create a Ground plane layer and tie it to ground signals with vias.
- To effectively transfer heat from the center thermal pad on the top layer to the ground plane, vias need to be used in the center pad. Use 5 to 9 vias spaced evenly with a finished diameter of 0.3mm.
- Place Test vias as close as possible to the IC to ensure a good measurement value.
- PVIN, VIN, VOUT signals have to be tracked with a widely and straight copper area
- Never trace the Feedback signal in parallel to the SW signal.
- Ensure the SW Inductor is placed as close as possible to its pads.
- SW track has to be as thin and short as possible.
- Make sure the I/O connectors are capable to manage the Load current.

Note: Freescale does not recommend connecting the PGND pins to the thermal pad. The thermal pad is connected to the signal ground and should not be used to make the connection from the PGND pins to the ground plane. Doing so can cause ground bounce on the signal ground from the high di/dt switch current and parasitic trace inductance.

6.2 Bill of Materials

Table 3. BILL OF MATERIALS KIT34716

EVB Number: KIT34716EPEVBE

Item	Qty	Reference	Value	Description	Footprint
1	23	VOUT1,SW1,PVIN1,INV1,ILIM1,COMP1,BOOT1,VOUT2,SW2,PVIN2,INV2,ILIM2,COMP2,BOOT2,VREFOUT,VREFIN,VIN,VDDI,STBY,SD,PG,GND,FREQ	not populated	PC Test point miniature SMT	TP
2	2	C2,C31	1.0 μ F	Cap Cer 1.0 μ F 6.3V 10% X5R 0603	SM/C_0603
3	12	C3,C4,C5,C6,C7,C8,C10,C24,C25,C29,C32,C33	100 μ F	Cap Cer 100 μ F 6.3V 10% X5R 1210	SM/C_1210
4	2	C9,C26	not populated		
5	10	C1,C11,C12,C13,C14,C15,C16,C27,C28,C30	0.1 μ F	Cap Cer 0.1 μ F 50V 10% X7R 0603	SM/C_0603
6	1	C17	10 μ F	Cap Cer 10 μ F 6.3V 20% X5R 0603	SM/C_0603
7	1	C18	15pF	Cap Cer 15pF 50V 1% C0G 0603	SM/C_0603
8	1	C19	750pF	Cap Cer 750pF 50V 5% C0G 0603	SM/C_0603
9	1	C20	910pF	Cap Cer 910pF 50V 5% C0G 0603	SM/C_0603
10	1	C21	20pF	Cap Cer 20pF 50V 5% C0G 0603	SM/C_0603
11	1	C22	1.8nF	Cap Cer 1800pF 50V 5% C0G 0603	SM/C_0603
12	1	C23	1.0nF	Cap Cer 1000pF 25V 5% C0G 0603	SM/C_0603
13	1	D1	LED	LED Green 0603 SMD	SM/C_0603
14	2	D2,D3	not populated		
15	1	J1	Pin Header (2 x 5)	HDR 2X5 TH 100mil CTR 330H AU	0.1" (2.54mm)
16	3	100mils jumpers	Jumpers		100mils
17	3	J2,J3,J4	not populated		

18	1	J5	not populated		
19	1	L1	1.0 μ H	Inductor Power 1.0 μ H 7.5A SMD	B82464G
20	1	L2	1.5 μ H	Inductor Power 1.5 μ H 7.0A SMD	B82464G
21	2	R1,R4	20k Ω	Res MF 20k Ω 1/10W 1% 0603 SMD	SM/C_0603
22	1	R2	12.7k Ω	Res MF 12.7k Ω 1/10W 1% 0603 SMD	SM/C_0603
23	2	R3,R20	not populated		
24	3	R5,R6,R21	not populated		
25	1	R7	1k Ω	Res MF 1.0k Ω 1/10W 1% 0603	SM/C_0603
26	1	R10	10k Ω	Res MF 10k Ω 1/10W 1% 0603	SM/C_0603
27	3	R12,R13,R22	not populated		
28	4	R8,R9,R11,R16	10k Ω	Res MF 10k Ω 1/10W 1% 0603	SM/C_0603
29	1	R14	560 Ω	Res MF 560 Ω 1/10W 1% 0603	SM/C_0603
30	1	R15	22k Ω	Res MF 22k Ω 1/10W 5% 0603	SM/C_0603
31	1	R17	17.4k Ω	Res MF 17.4k Ω 1/10W 1% 0603	SM/C_0603
32	1	R18	300 Ω	Res MF 300 Ω 1/10W 5% 0603	SM/C_0603
33	1	R19	15k Ω	Res MF 15k Ω 1/10W 1% 0603	SM/C_0603
34	1	SD	Push_Button	Switch Tact Mini 200GF SLV Gwing	
35	1	STBY	not populated	Switch Tact Mini 200GF SLV Gwing	
36	1	U2	MC34716		QFN_26

Notes: Freescale does not assume liability, endorse, or warrant components from external manufacturers that are referenced in circuit drawings or tables. While Freescale offers component recommendations in this configuration, it is the customer's responsibility to validate their application.

7 Conclusion

With this User Guide, the user will be capable of configuring the 34716 as power supply for DDR memory chips, as well as other devices that can make use of some of the capabilities that the 34716 offers. The board is fully configured to work at any desirable input voltage within 3.0 and 6.0 V. However, it is highly recommended to calculate all components for the specific application situation in order to assure a better efficiency and stability of the IC.

8 References

- 34716 Datasheet, 3A and 5A 1MHz Fully Integrated Double Switch-mode Power Supply, Freescale Semiconductor, Inc.
- Application Note “AN1989 MC34701 and MC34702 Component Selection Guide”, Freescale Semiconductor, Inc.
- Sanjaya Maniktala, “*Switching Power Supplies A to Z*”, Newnes, 2006.

How to Reach Us:

Home Page:

www.freescale.com

Web Support:

<http://www.freescale.com/support>

USA/Europe or Locations Not Listed:

Freescale Semiconductor, Inc.
Technical Information Center, EL516
2100 East Elliot Road
Tempe, Arizona 85284
+1-800-521-6274 or +1-480-768-2130
www.freescale.com/support

Europe, Middle East, and Africa:

Freescale Halbleiter Deutschland GmbH
Technical Information Center
Schatzbogen 7
81829 Muenchen, Germany
+44 1296 380 456 (English)
+46 8 52200080 (English)
+49 89 92103 559 (German)
+33 1 69 35 48 48 (French)
www.freescale.com/support

Japan:

Freescale Semiconductor Japan Ltd.
Headquarters
ARCO Tower 15F
1-8-1, Shimo-Meguro, Meguro-ku,
Tokyo 153-0064
Japan
0120 191014 or +81 3 5437 9125
support.japan@freescale.com

Asia/Pacific:

Freescale Semiconductor Hong Kong Ltd.
Technical Information Center
2 Dai King Street
Tai Po Industrial Estate
Tai Po, N.T., Hong Kong
+800 2666 8080
support.asia@freescale.com

For Literature Requests Only:

Freescale Semiconductor Literature Distribution Center
P.O. Box 5405
Denver, Colorado 80217
1-800-441-2447 or 303-675-2140
Fax: 303-675-2150
LDCForFreescaleSemiconductor@hibbertgroup.com

RoHS-compliant and/or Pb-free versions of Freescale products have the functionality and electrical characteristics of their non-RoHS-compliant and/or non-Pb-free counterparts. For further information, see <http://www.freescale.com> or contact your Freescale sales representative.

For information on Freescale's Environmental Products program, go to <http://www.freescale.com/epp>.

Information in this document is provided solely to enable system and software implementers to use Freescale Semiconductor products. There are no express or implied copyright licenses granted hereunder to design or fabricate any integrated circuits or integrated circuits based on the information in this document.

Freescale Semiconductor reserves the right to make changes without further notice to any products herein. Freescale Semiconductor makes no warranty, representation or guarantee regarding the suitability of its products for any particular purpose, nor does Freescale Semiconductor assume any liability arising out of the application or use of any product or circuit, and specifically disclaims any and all liability, including without limitation consequential or incidental damages. "Typical" parameters that may be provided in Freescale Semiconductor data sheets and/or specifications can and do vary in different applications and actual performance may vary over time. All operating parameters, including "Typicals", must be validated for each customer application by customer's technical experts. Freescale Semiconductor does not convey any license under its patent rights nor the rights of others. Freescale Semiconductor products are not designed, intended, or authorized for use as components in systems intended for surgical implant into the body, or other applications intended to support or sustain life, or for any other application in which the failure of the Freescale Semiconductor product could create a situation where personal injury or death may occur. Should Buyer purchase or use Freescale Semiconductor products for any such unintended or unauthorized application, Buyer shall indemnify and hold Freescale Semiconductor and its officers, employees, subsidiaries, affiliates, and distributors harmless against all claims, costs, damages, and expenses, and reasonable attorney fees arising out of, directly or indirectly, any claim of personal injury or death associated with such unintended or unauthorized use, even if such claim alleges that Freescale Semiconductor was negligent regarding the design or manufacture of the part.

Freescale™ and the Freescale logo are trademarks of Freescale Semiconductor, Inc. All other product or service names are the property of their respective owners.

© Freescale Semiconductor, Inc., 2007-2009. All rights reserved.