

THIS DRAWING IS UNPUBLISHED. RELEASED FOR PUBLICATION ,19 .
 © COPYRIGHT 19 BY AMP INCORPORATED. ALL INTERNATIONAL RIGHTS RESERVED.

LOC	DIST	P	F	ZONE	LTR	DESCRIPTION	DATE	APPD
G	14				E	REV & REDRAWN PER 0720-0061-93	4-19-93	APP DAP

METRIC
 DIMENSIONS LISTED IN mm [INCHES]

AMP WIRE RANGE	UL E13288 Listed
2 AWG SOLID OR STRANDED	NOT APPLICABLE
SR LR7189 Certified	MILITARY P/N AND CLASS
NOT APPLICABLE	NOT APPLICABLE

① STAMP AMP 2W* APPROX AS SHOWN

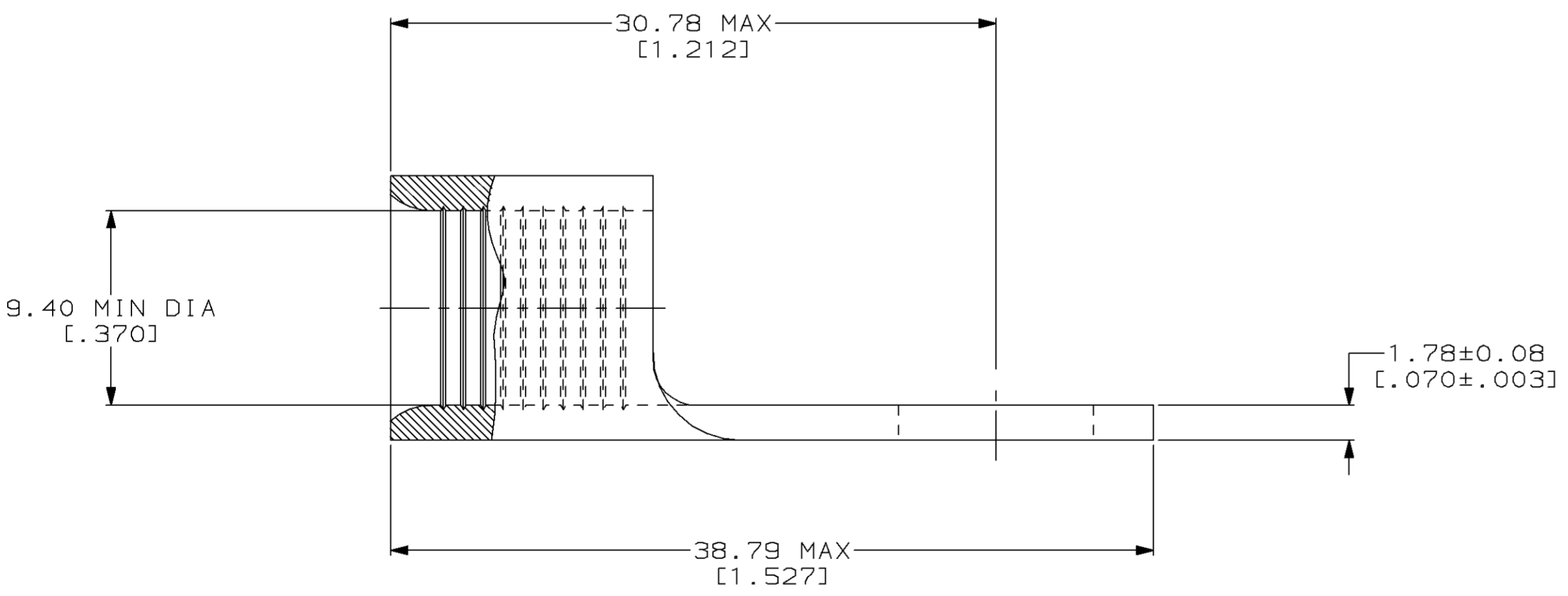
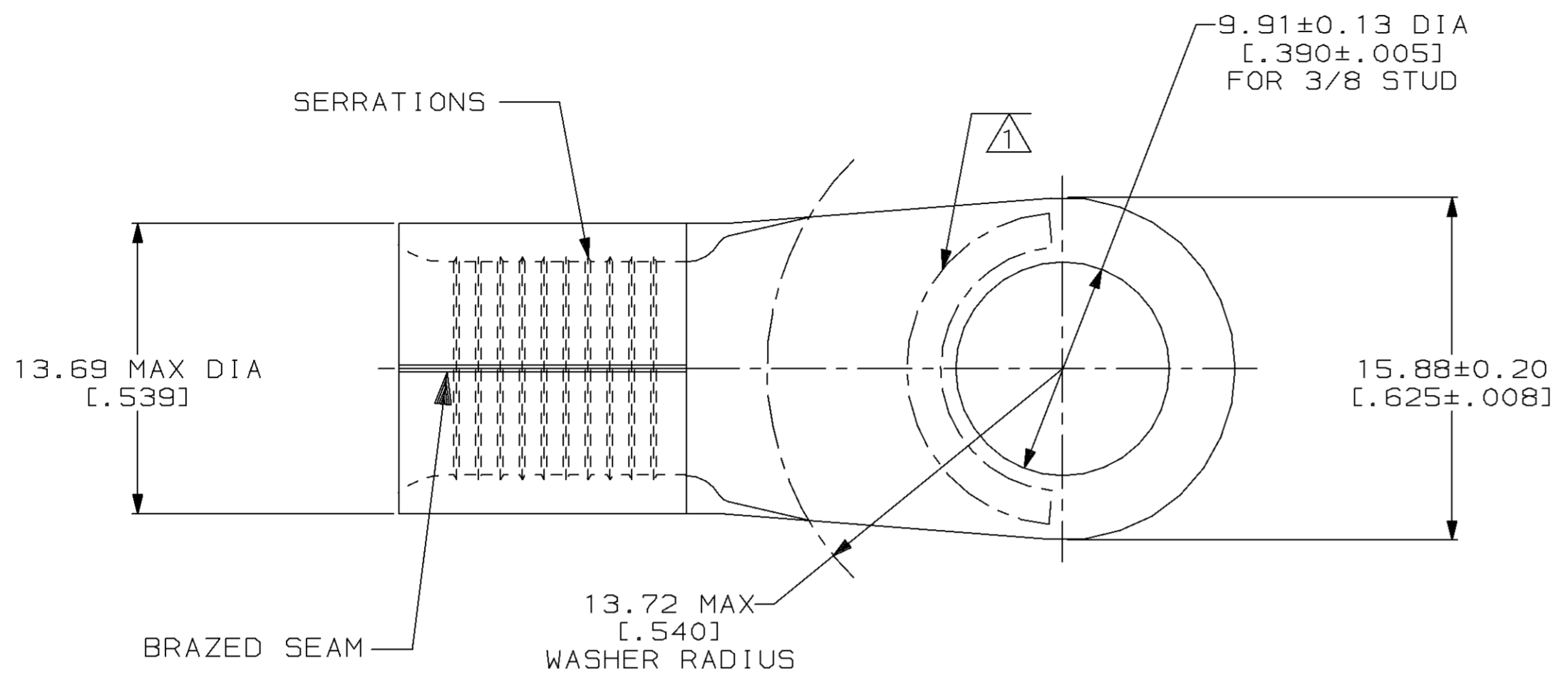

AMP INCORPORATED CUSTOMER SERVICE SYSTEMS		MAX RECOMMENDED OPERATING TEMPERATURE: 343°C MAX		DO NOT SCALE PRINT. UNLESS SPECIFIED DIMENSIONS IN mm [INCHES] TOLERANCES ON: 2 PLC DEC ± - 3 PLC DEC ± - ANGLES ± -		DR 4-19-93 TA BRINKMAN		323177 PART NO	
FOR ADDITIONAL PRODUCT INFORMATION OR COPIES OF DRAWINGS AND TECHNICAL DOCUMENTS		PRODUCT INFORMATION CENTER 1-800-522-6752		VOLTAGE RATING: NOT APPLICABLE		MATERIAL COPPER PER ASTM B-152 ANNEALED		AMP Incorporated Harrisburg, PA 17105-3608	
FOR APPLICATION TOOLING INFORMATION		TOOLING ASSISTANCE CENTER 1-800-722-1111		WIRE CROSS SECTIONAL AREA RANGE: 26.7-42.4mm² [52,600-83,700] CIR MILS SOLID OR STRANDED		FINISH NICKEL PLATE 0.00762[0.000300] MIN THK PER QQ-N-290		NAME TERMINAL, RING TONGUE, HEAT RESISTANT, STRATO-THERM™	
FOR ORDER ENTRY		1-800-526-5142		THIS DRAWING IS A CONTROLLED DOCUMENT FOR AMP INCORPORATED. IT IS SUBJECT TO CHANGE AND THE CONTROLLING ENGINEERING ORGANIZATION SHOULD BE CONTACTED FOR THE LATEST REVISION.		APPD 4-19-93 DA PATTERSON		SIZE CAGE CODE DRAWING NO	
						APPD 4-19-93 JL MECKLEY		C=323177	
						PRODUCT SPEC -		SCALE 4:1	
						APPLICATION SPEC -		SHEET 1 OF 1	
						WEIGHT -		CUSTOMER DRAWING	