

© 1967 BY AMP INCORPORATED. ALL RIGHTS RESERVED. AMP PRODUCTS COVERED BY PATENTS AND OR PATENTS PENDING.

REVISIONS				
ZONE	LTP	DESCRIPTION	DATE	APPROVED
B		REDRAWN & REV P6077	SK 7-31-69	FJL
C		REVISED PC-5579	12-2-70	
D		ADDED TAPE NO'S & REV P-5578	7-6-71	FJL
E		REVISED PC-5578	7-23-77	L.D.
F		INACTIVATED -3 P-9257	5-21-82	
G		OBS. -3 REV G2582	BT 10-7-87	
H		OBS -2 G-2974	Rmf 4/4/88	
J		OBS. 50839 G-2976 OBS. -1 G-2984	TRC 5-26-88	
K		REACT. / 0720-0366-94	LD 3-25-94	ML
L		REV / 0610-0094-98	2-5-99	ML/MS
L1		REV Pwr ECR 05-013140	10/2/05	JE/TM

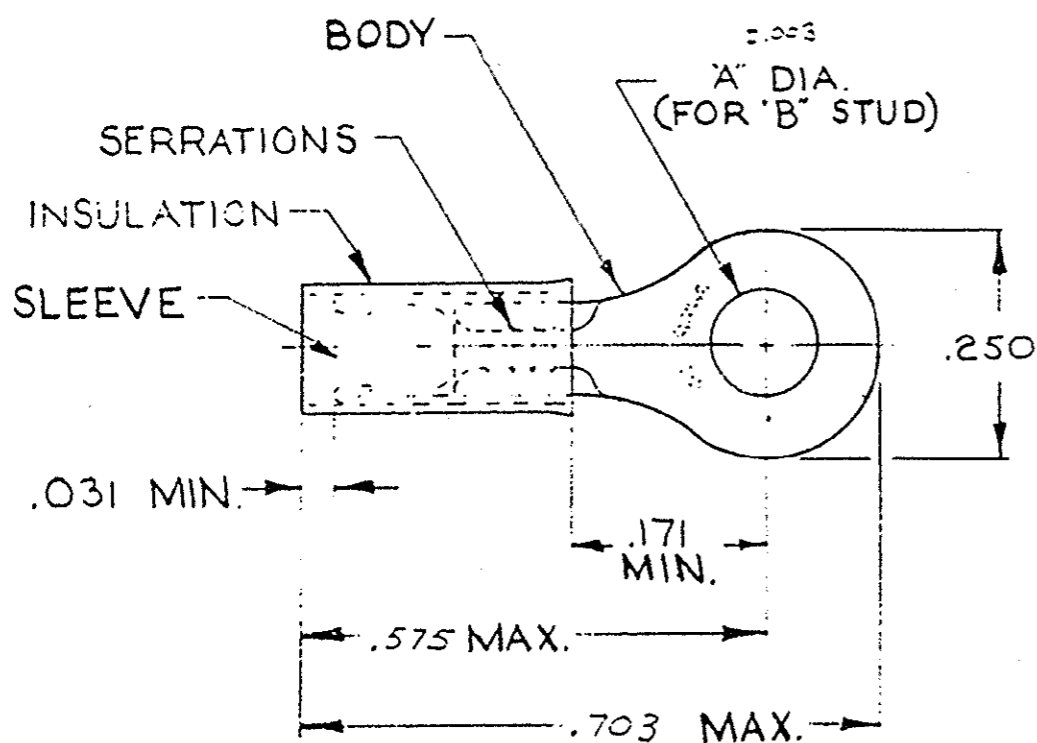

FOR .080 TO .150 WIRE INSULATION DIA.
TONGUE MATERIAL THK. = .031 ±.002

TABLE I

1	WIRE TERMINAL	SEE TABLE II	BODY: COPPER (ASTM B 152) NICKEL PLATE (QQ-N-290) .0003 AVG. EXT. THK
			SLEEVE: COPPER (ASTM B 152) NICKEL PL (QQ-N-290). 00003 AVG. EXT. THK.
			INSULATION: TEFLON (ASTM-D3295) COLOR: WHITE
QTY	DESCRIPTION	PART NO.	MATERIAL & FINISH
UNLESS OTHERWISE SPECIFIED DIMENSIONS ARE IN INCHES TOLERANCES ON: DECIMALS ±.008 ANGLES ± 5°			CONTRACT NO. <u>11</u>
MATERIAL			AMP INCORPORATED HARRISBURG, PENNSYLVANIA
SEE TABLE I			DR. <u>Steve Paul</u> 7-3-69 CHK. <u>F. J. Campbell</u> 7-3-69 APPR. <u>Swabner</u> 8-6-69 REL. <u>John G. ...</u> 8-6-69
			NAME WIRE TERMINAL PIDG™ STRATO-THERM-RING TONGUE WIRE SIZE: 14
			SIZE B CODE IDENT NO. 00779 NUMBER 50839
			SCALE NTS SHEET

TABLE II

50839-1	.145	*6	50839-3	OBSOLETE
50839	.119	*4	50839-2	OBSOLETE
PART NO.	"A"	"B"	PART NO ON TAPE	