

THIS DRAWING IS UNPUBLISHED. RELEASED FOR PUBLICATION
 © COPYRIGHT - By - ALL RIGHTS RESERVED.

LOC	DIST	REVISIONS					
		P	LTR	DESCRIPTION	DATE	DWN	APVD
G	14		D3	REVISED PER ECO-12-004648	08MAR12	KH	DR

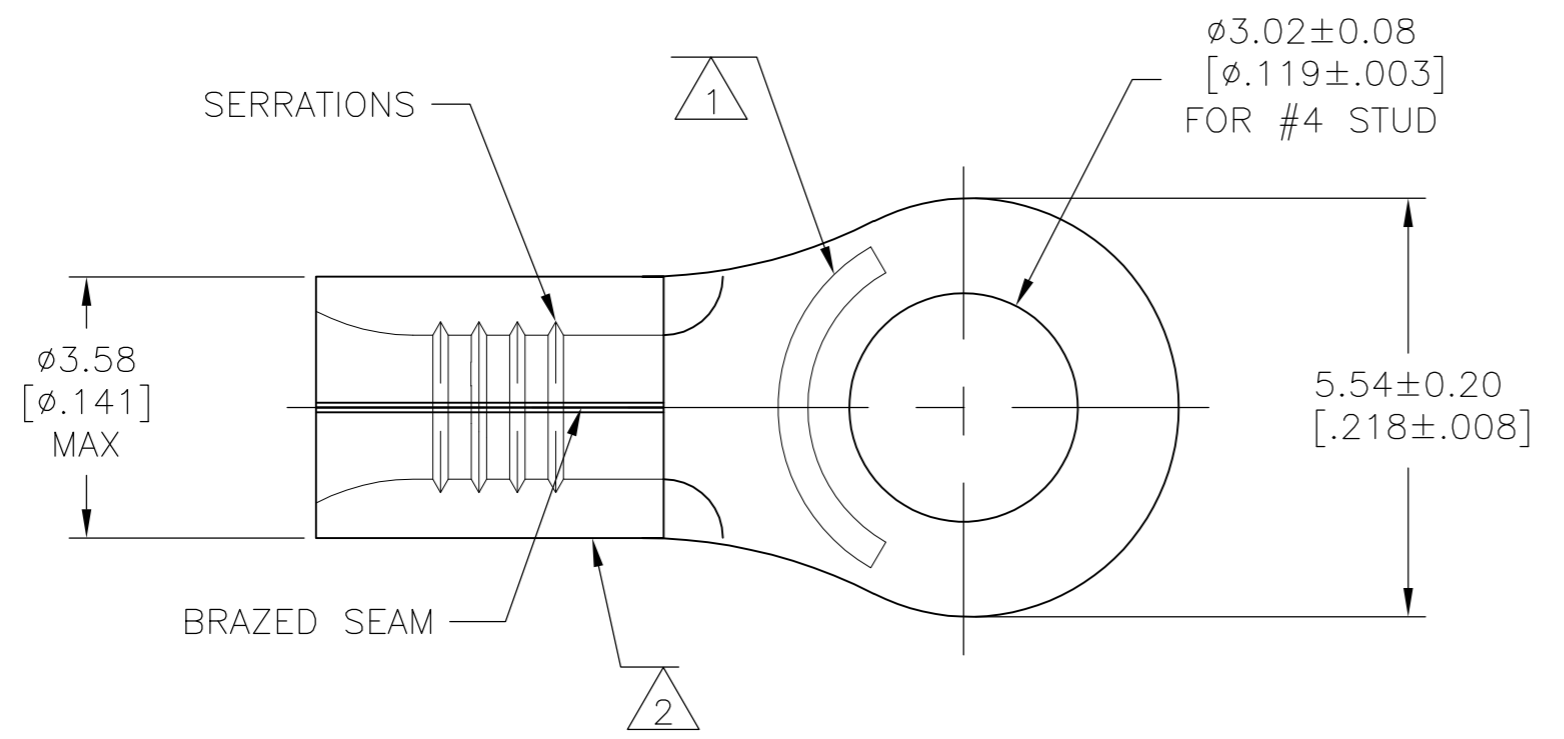

AMP
 WIRE RANGE
 22-16 AWG
 SOLID OR STRANDED

- 1 STAMP AMP 22-18 APPROX AS SHOWN
 22-16 TERMINALS ARE STAMPED 22-18 IN ACCORDANCE WITH MILITARY SPECIFICATION SAE AS7928 COMMERCIAL WIRE RANGE IS 22-16.
- 2 WIRE BARREL COLOR CODED ORANGE TO DENOTE NICKEL MATERIAL
- 3 GOLD PLATE 0.00127[.000050] MIN EXT THK PER ASTM B488 TYPE1, CODE C OVER NICKEL FLASH PER SAE AMS QQ-N-290 OVER WOODS NICKEL FLASH PER ASTM B558
- 4 NOTE DELETED

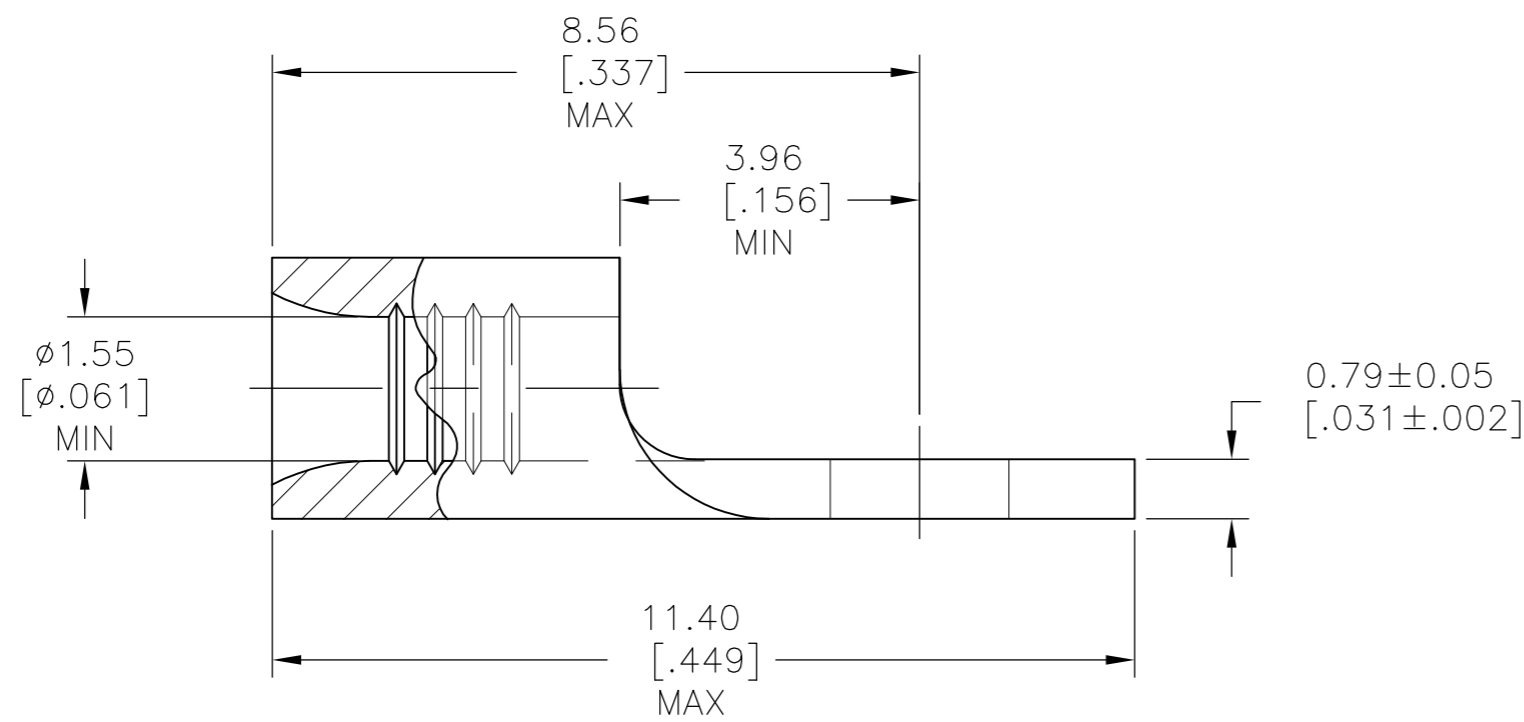

AMP INCORPORATED CUSTOMER SERVICE SYSTEMS		MAX RECOMMENDED OPERATING TEMPERATURE: SEE TABLE
FOR ADDITIONAL PRODUCT INFORMATION OR COPIES OF DRAWINGS AND TECHNICAL DOCUMENTS	PRODUCT INFORMATION CENTER 1-800-522-6752	VOLTAGE RATING: NOT APPLICABLE
FOR APPLICATION TOOLING INFORMATION	TOOLING ASSISTANCE CENTER 1-800-722-1111	WIRE CROSS SECTIONAL AREA RANGE: 0.26-1.65mm ² [509-3,260] CIR MILS SOLID OR STRANDED
FOR ORDER ENTRY	1-800-526-5142	THIS DRAWING IS A CONTROLLED DOCUMENT FOR AMP INCORPORATED. IT IS SUBJECT TO CHANGE AND THE CONTROLLING ENGINEERING ORGANIZATION SHOULD BE CONTACTED FOR THE LATEST REVISION.

FINISH	MAX OPERATING TEMP	QUANTITY	PACKAGE TYPE	PART NO
2	649°C [1200°F]	5000	ON TAPE	2-321884-2
3	260°C [500°F]	1000	LOOSE PIECE	321884-1
2	649°C [1200°F]	1000	LOOSE PIECE	321884

THIS DRAWING IS A CONTROLLED DOCUMENT.		DWN TA BRINKMAN 4-15-93	TE TE Connectivity	
DIMENSIONS: mm [INCHES]		CHK DA PATTERSON 4-15-93		
TOLERANCES UNLESS OTHERWISE SPECIFIED:		APVD DE MILLER 4-15-93	NAME TERMINAL, RING TONGUE, HIGH TEMPERATURE, STRATO-THERM	
0 PLC ± - 1 PLC ± - 2 PLC ± - 3 PLC ± - 4 PLC ± - ANGLES ± -		PRODUCT SPEC APPLICATION SPEC	SIZE A2	CAGE CODE 00779
MATERIAL NICKEL PER ASTM B-162 ANNEALED		FINISH SEE TABLE	DRAWING NO C=321884	RESTRICTED TO -
		WEIGHT -	SCALE 10:1	SHEET 1 OF 1
		CUSTOMER DRAWING	REV D3	