

PART NUMBER	REV	TERMINATOR	FEED TYPE	DESCRIPTION
1339823-1	A	BENCH & LEADMAKER	MECH POST FEED	HDI APPLICATOR
7-1339823-1	A	BENCH & LEADMAKER	MECH POST FEED	-1 AND SPARE PARTS
7-1339823-7	A	-	-	SPARE PARTS KIT

LOC	DIST	REV	DATE	BY	APPD
A	66	A	27NOV2007	LJL	MC

CRIMP DATA ESCUBEDO TERMINAL TE CRIMP SPECS

CRIMP	SIZE	TYPE	RANGE
WIRE	2.29 [.090 IN]	F	0.50-1.00mm <sup>2</sup> or 20-18 AWG
INSUL	3.56 [.140 IN]	F	1.80-2.50 [.071-.098 IN]

WIRE STRIP LENGTH 4.80-5.60 [.189-.220 IN] APPL INSTRUCTIONS 408-8323

TERMINAL APPL SPEC - FEED 18.75 [.738 IN]

TERMINALS APPLIED

TE TERM PN	MANUF TERM PN	TE TERM PN	MANUF TERM PN
1949074-1	4840.00	1949074-5	4840.70
1949074-2	4840.02	-	-
1949074-3	4840.30	-	-
1949074-4	4840.32	-	-

WIRE SIZE	CRIMP HEIGHT	PIN PN & LENGTH [IN]
1.00mm <sup>2</sup>	1.52 ± 0.05 [.060 ± .002 IN]	354779-9 [.3035]
0.75mm <sup>2</sup>	1.45 ± 0.05 [.057 ± .002 IN]	1-354779-4 [.3060]
0.50mm <sup>2</sup>	1.35 ± 0.05 [.053 ± .002 IN]	2-354779-4 [.3110]

- 1 RECOMMENDED SPARE PARTS
- 2. GREASE RAM, CAM, CAM FOLLOWER AND FEED ROD LIGHTLY.
- 3 CERTAIN TERMINALS REQUIRE LUBRICATION. REFER TO THE APPLICATOR INSTRUCTION SHEET FOR MORE INFORMATION.
- 4. LUBRICATE DAILY PER THE APPLICATOR INSTRUCTION SHEET SUPPLIED WITH THE APPLICATOR.
- 5 CRIMP DATA CALCULATED BY TYCO ELECTRONICS UK LTD.

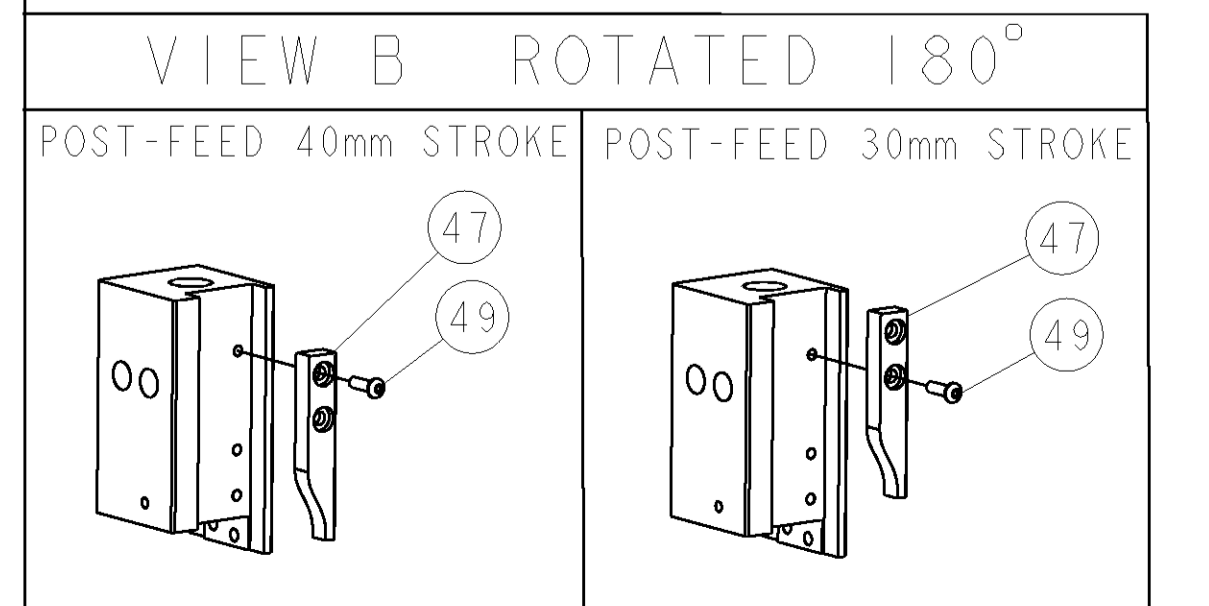
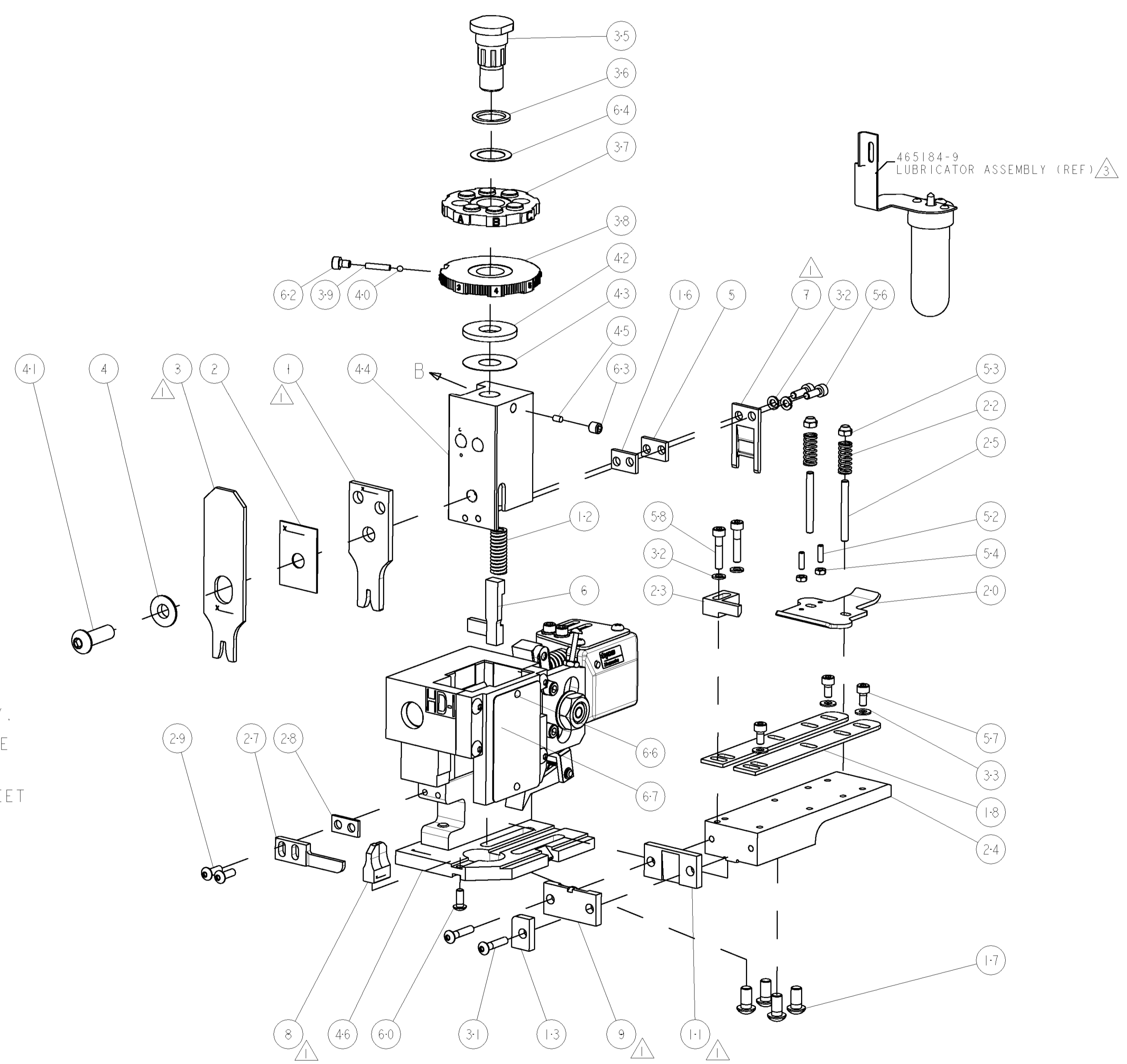

-	1	1	1338705-2	DOCUMENTATION PACKAGE	71	
-	1	1	461264-1	PLATE, IDENTIFICATION	67	
-	2	2	21017-2	SCREW, DRIVE	66	
-	1	1	986950-1	WASHER, FLAT PRECISION	64	
-	1	1	3-18031-0	SCR, SET, CUP POINT M6 X 6.0	63	
-	1	1	18023-9	SCR, SKT HD CAP M4 X 6.0	62	
-	1	1	18024-7	SCR, BTN SKT HD CAP (M4 X 10.0)	60	
-	2	2	1-18023-4	SCR, SKT HD CAP M4 X 20.0	58	
-	3	3	1-18023-0	SCR, SKT HD CAP M4 X 8.0	57	
-	2	2	1-18023-2	SCR, SKT HD CAP M4 X 12.0	56	
-	2	2	18029-1	NUT, HEX, REG M3	54	
-	2	2	986965-1	NUT, LOCK, HEX, TORQUE (M4)	53	
-	2	2	2-18032-2	SCR, SET, FLT POINT M3 X 10.0	52	
-	1	1	18024-3	SCR, BTN SKT HD CAP (M3 X 10.0)	49	
-	1	1	1338676-1	CAM, UNIVERSAL POST-FEED	47	
-	1	1	1338662-1	SUB ASSY, APPLICATOR FRAME	46	
-	1	1	690191-1	PLUG, NYLON	45	
-	1	1	1320998-1	RAM	44	
-	1	1	690125-1	SHIM SUB-ASSY	43	
-	1	1	690124-1	WASHER, RAM (.115)	42	
-	1	1	2-18024-6	SCR, BTN SKT HD CAP (M8 X 25.0)	41	
-	1	1	23241-1	BALL, STEEL	40	
-	1	1	2-22278-7	SPRING, COMPRESSION	39	
-	1	1	1320922-1	DISC, ADJUST, INSULATION CRIMP	38	
-	1	1	354777-1	WIRE DISC, ASSEMBLY	37	
-	1	1	22480-5	SPRING, COMPRESSION	36	
-	1	1	690212-1	POST, RAM	35	
-	3	3	18027-2	WASHER, FLAT, REG M4	33	
-	4	4	18025-2	WASHER, SPRG LOCK, REG M4	32	
-	2	2	1-18024-0	SCR, BTN SKT HD CAP (M4 X 20.0)	31	
-	2	2	18024-8	SCR, BTN SKT HD CAP (M4 X 12.0)	29	
-	1	1	3-690451-2	SPACER, STRIPPER	28	
-	1	1	240639-1	STRIPPER (MACHINING)	27	
-	2	2	1320906-1	STUD, THREADED	25	
-	1	1	1320995-1	PLATE, STRIP GUIDE	24	
-	1	1	240825-1	PLATE, STRIP HOLD DOWN	23	
-	2	2	4-22281-1	SPRING, DRAG	22	
-	1	1	1338665-1	DRAG	20	
-	2	2	1338663-4	GUIDE, LOWER STRIP	18	
-	4	4	1-18024-8	SCR, BTN SKT HD CAP (M6 X 12.0)	17	
-	1	1	1338708-1	SPACER, SLUG BLADE	16	
-	1	1	1-690481-9	SPACER, HOLD DOWN	13	
-	1	1	23846-1	SPRING, DIE	12	
-	1	1	240644-1	PLATE, REAR SHEAR	11	
-	-	-	-	-	10	
-	1	1	4-690495-1	PLATE, FRONT SHEAR	9	
-	1	2	2-1633384-6	ANVIL, COMBINATION	8	
-	1	1	690474-6	BLADE, SLUG	7	
-	1	1	1-455892-1	HOLD DOWN, TERMINAL	6	
-	1	1	8-240641-6	SPACER	5	
-	1	1	238009-4	BLOCK, FL CRIMPER SPACER	4	
-	1	2	9-1213077-7	CRIMPER, INSULATION PREMIUM	3	
-	1	1	455888-7	SPACER, CRIMPER	2	
-	1	2	1-456406-6	CRIMPER, WIRE PREMIUM	1	
-	77	71	-1	PART NO	DESCRIPTION	ITEM NO

TYCO ELECTRONICS CORPORATION, 1000 W. CLIFFORD AVE., HARRISBURG, PA 17105-3608

APPLICATOR INSTRUCTION SHEET

END FEED HDI APPLICATOR

SCALE 3:5 SHEET 1 OF 1 REV A