

THIS DRAWING IS UNPUBLISHED. RELEASED FOR PUBLICATION  
 © COPYRIGHT - By - ALL RIGHTS RESERVED.

LOC	DIST	REVISIONS					
AJ	00	P	LTR	DESCRIPTION	DATE	DWN	APVD
		G3		REVISED PER ECO-11-005030	11MAR11	RK	HMR

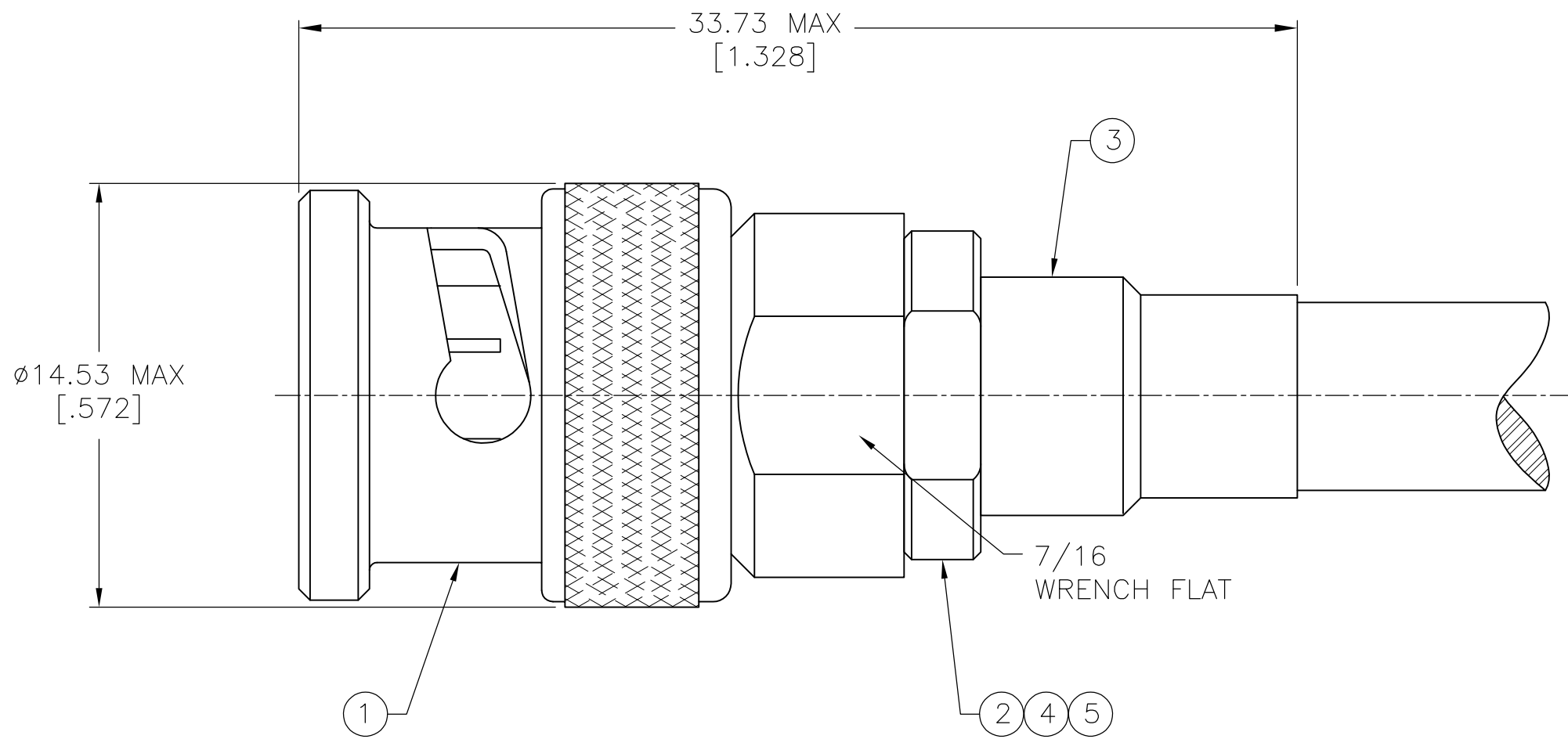

NOTES:

1. USE CRIMPING TOOL 69667.
2. SEE INSTRUCTION SHEET 408-2055.
3. PARTS PACKAGED SEPARATELY.
4. OBSOLETE PARTS: OBSOLETE CIS STREAMLINING PER D.RENAUD/D.SINISI

4	OBSOLETE	ROLM 49D2401 TWINAX	332214	332222-1	9-332224-0	1-332221-5	5-330949-0	332225-6					
		RG 108/U & 108A/U	332214	332222-1	9-332224-0	1-332221-4	5-330949-0	332225-5					
	OBSOLETE	TROMPETER TWC-124-2	332214	332222	1-332224-0	1-332221-3	2-330949-2	332225-3					
		RG 108/U & 108A/U	332214	332222	1-332224-0	332221	2-330949-2	332225					
		FOR USE WITH CABLE	5	SEAL QTY=1	4	DIELECTRIC QTY=1	3	FERRULE QTY=1	2	CRIMP END QTY=1	1	PLUG ASSY QTY=1	PART #

THIS DRAWING IS A CONTROLLED DOCUMENT.

DIMENSIONS: mm	TOLERANCES UNLESS OTHERWISE SPECIFIED:	DWN G. VIERA 10JUL03	 TE Connectivity
	0 PLC ± -	CHK J. HAVENER 10JUL03	
	1 PLC ± -	APVD J. HAVENER 10JUL03	
	2 PLC ± -	NAME	
	3 PLC ± -	PRODUCT SPEC	PLUG, TWIN BNC
	4 PLC ± -	APPLICATION SPEC	
	ANGLES ± 1°	WEIGHT 0.50 OZ.	SIZE A3 CAGE CODE 00779 DRAWING NO C-332225 RESTRICTED TO -
MATERIAL -	FINISH -	CUSTOMER DRAWING	SCALE 5:1 SHEET 1 OF 1 REV G3